

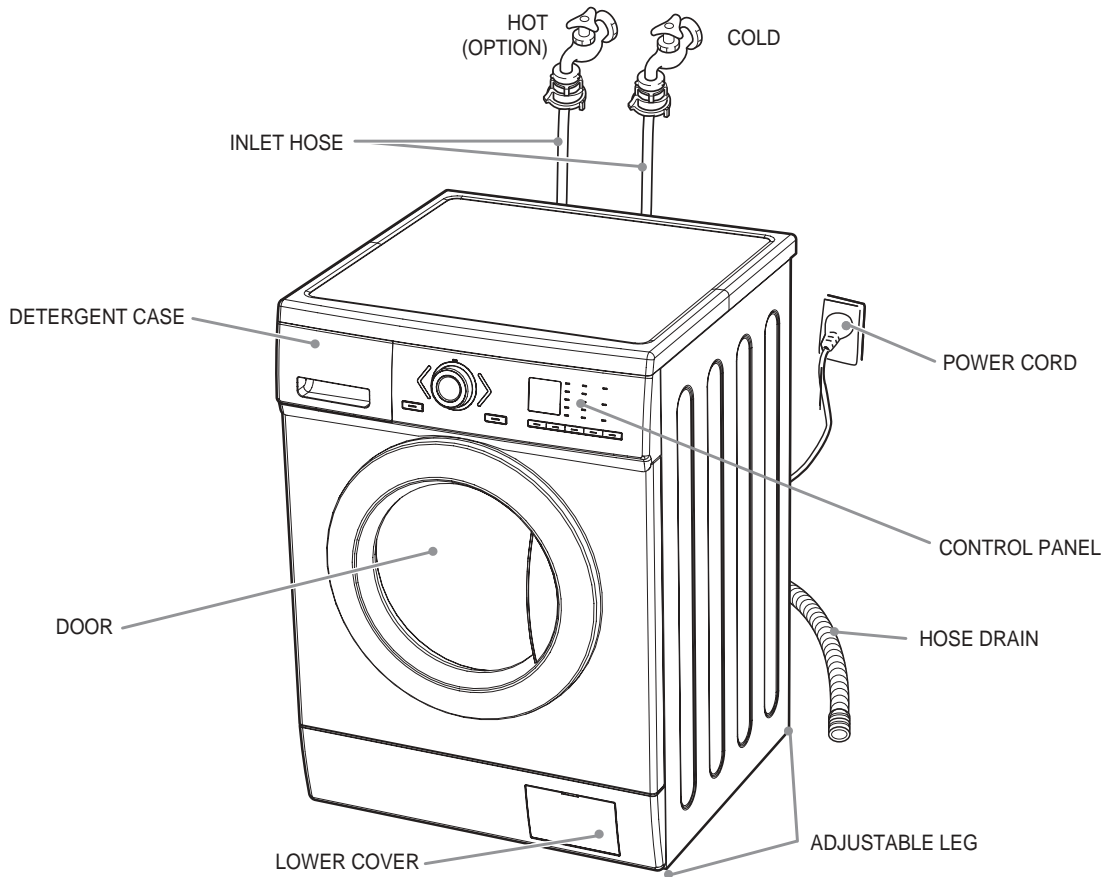

## ■ DWD-FD145X SERIES

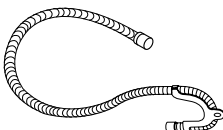
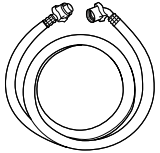

MODEL		DWD-FD1451/1452/1453/1454/1455	
POWER SOURCE		220-240V/50-60Hz	
DIMENSION (WXDXH)		595mm x 540mm x 850mm	
WEIGHT		58 kg	
WATER CONSUMPTION		56.1 ℓ	
POWER CONSUMPTION		2200W	
MAXIMUM MASS OF TEXTILE	WASH	7 kg	
	SPIN	7 kg	
WASHER TYPE		DRUM TYPE (FRONT LOADING WASHING MACHINE)	
OPERATING WATER PRESSURE		0.3 ~ 8kgf/cm <sup>2</sup> (29.4 ~ 784kPa)	

## ■ Accessories

Hose drain	Inlet hose	Manual	Cap holder(3EA)
			

## 2. INSTALLATION

### ■ Transit bolts

The appliance is fitted with transit bolts to prevent internal damage during transport.

### ■ Removing transit bolts

1. To prevent internal damage during transport, the special 3 bolts are locked. Before operating the washer, remove the bolts along with the rubber bungs.

- If they are not removed, it may cause heavy vibration, noise and malfunction.

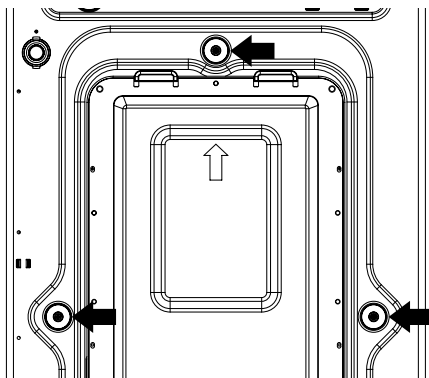

2. Unscrew the 3 bolts with the 10mm hex wrench or spanner or cross-tip screwdriver. Keep the 3 bolts for a later time.

- When the appliance is transported, transit bolts will be re-used.

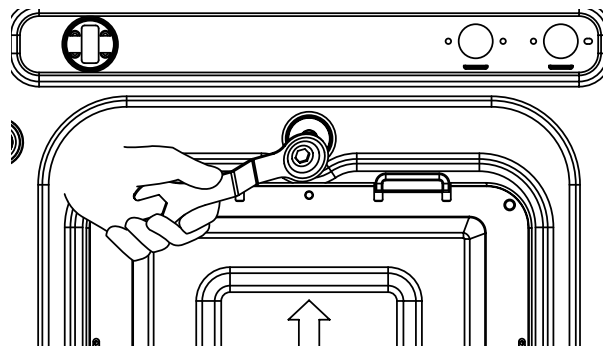

3. Close the holes with the caps supplied.

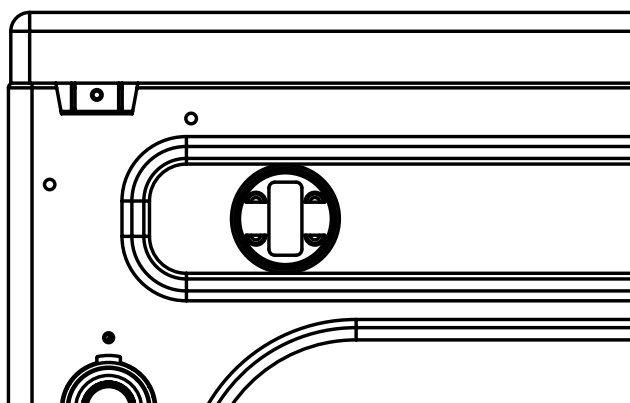

## ■ Installation place requirement

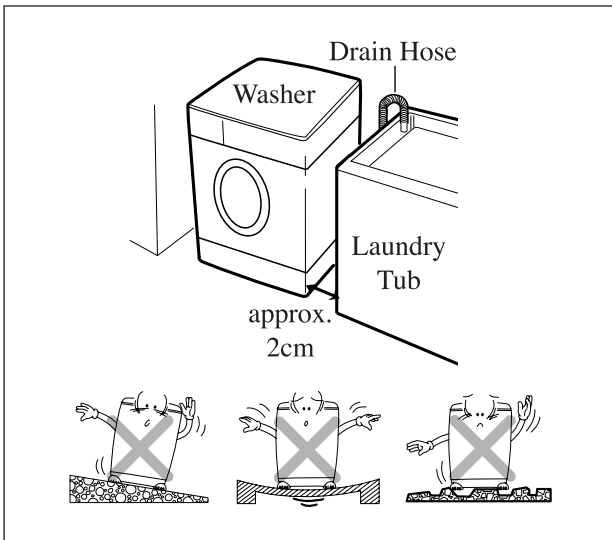

### Level floor :

Allowable slope under entire washer is 1°.

### Power outlet :

Must be with 1.5 meters of entire side of location of washer. Do not overload the outlet with more than one appliance.

### Additional Clearance :

For wall, door and floor modeling is required. (10cm : rear / 2cm : right & left side)

Do not place or store laundry products on top of washer at any times.

They can damage the finish or controls.

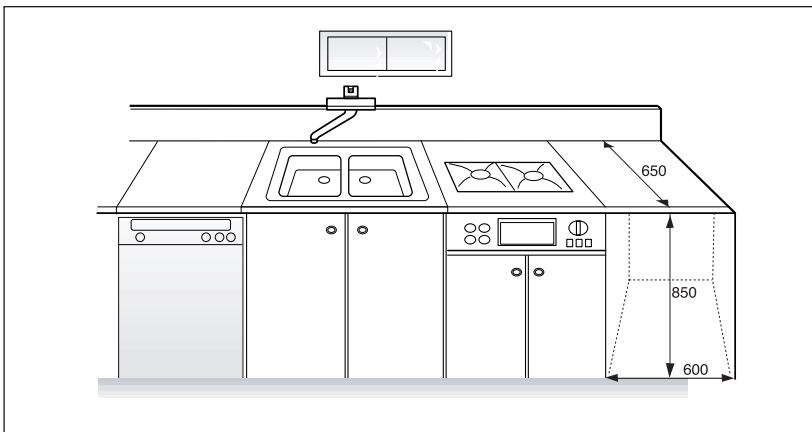

## ■ BS Plug Safety Details (For U.K. User)

### IMPORTANT

THE WIRES IN THIS MAINS LEAD ARE COLOURED IN ACCORDANCE WITH THE FOLLOWING CODE:

**GREEN AND YELLOW : EARTH**

**BLUE : NEUTRAL**

**BROWN : LIVE**

This appliance must be earthed

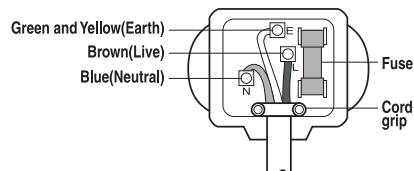

As the colours of the wires in the mains lead of this apparatus may not correspond with the coloured markings identifying the terminals in your plug, proceed as follows:

The wire which is coloured Green and Yellow must be connected to the terminal in the plug which is marked with the letter E or by the earth symbol  $\oplus$  or coloured Green or Green and Yellow.

The wire which is coloured Blue must be connected to the terminal which is marked with the letter N or coloured Black.

The wire which is coloured Brown must be connected to the terminal which is marked with the letter L or coloured Red.

If a 13 amp (BS 1363) plug is used, fit a 13amp BS 1362 fuse.

## ■ Connecting inlet hose

In using only one water tap or in case of only one water inlet valve, connect the inlet hose to the cold water inlet valve.  
Option : Be careful not to confuse hot water inlet and cold water inlet.

### •••• FOR ORDINARY TAP

- ① Pull down the collar of the inlet hose to separate it from the water tap adapter.

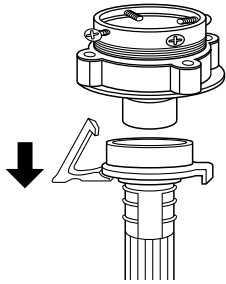

- ② Loosen the four screws properly in order to fit into water tap.

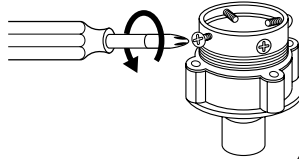

- ③ Fit the water tap adapter into the water tap and tighten the four screws evenly while pushing up the adapter so that the rubber packing can stick to the water tap tightly.

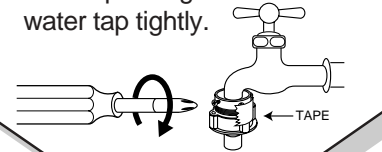

- ④ Remove the tape, and screw connector B into connector A tightly.

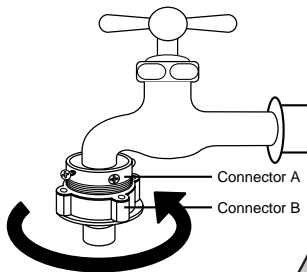

- ⑤ Connect the inlet hose to the water tap adapter by pulling down the collar of the hose end.

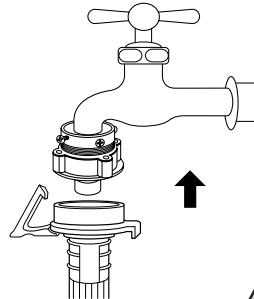

- ⑥ Connect the inlet hose adapter of the hose to the water inlet of the washer by turning it clockwise to be fixed tightly.

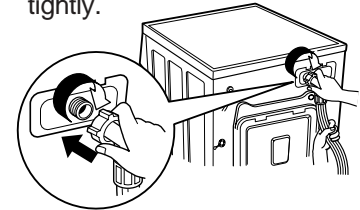

- Please check the rubber packing present inside the inlet hose adapter of the hose.

### •••• FOR SCREW-SHAPED TAP

- ① Connect the inlet hose to the water tap adapter by pulling down the collar of the hose end.

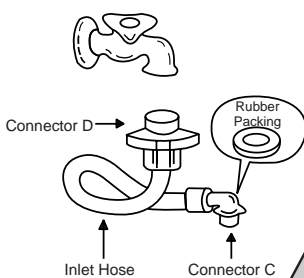

- ② Connect the connector-inlet supplied if necessary.

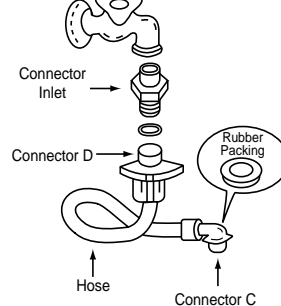

- ③ Connect the inlet hose adapter to the water inlet of the washer and turn it to be fixed.

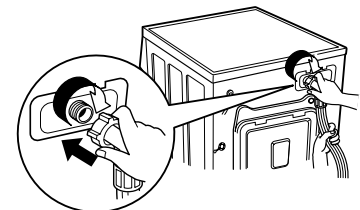

- Check the packing in the inlet.

## ■ Installation of drain hose

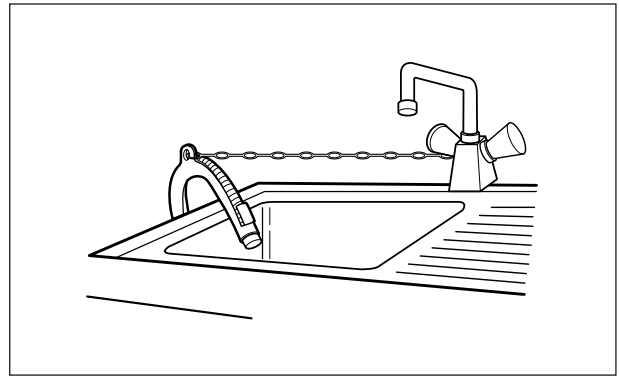
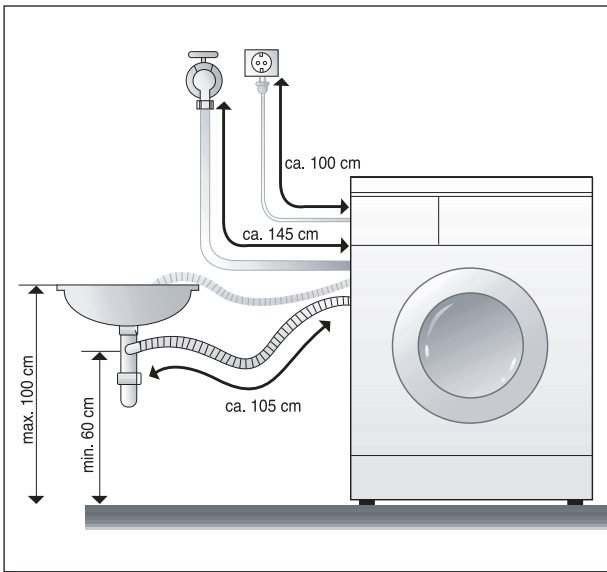

- When installing the drain hose in sink, secure it tightly with a string.
- Proper securing of the drain hose will **protect the floor from damage due to water leakage.**

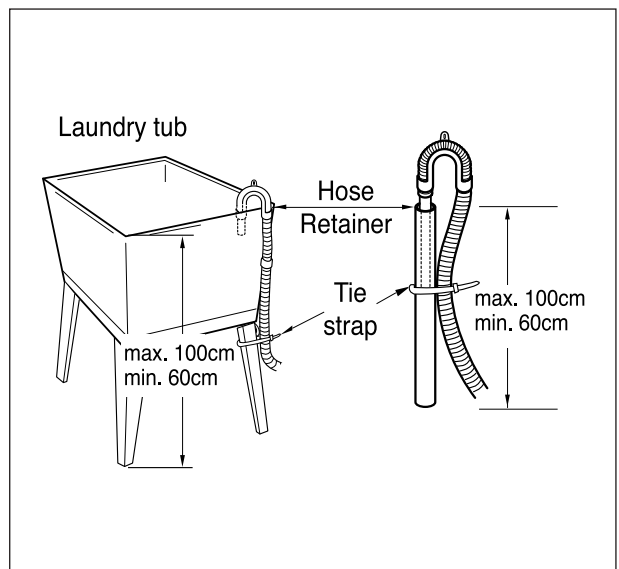
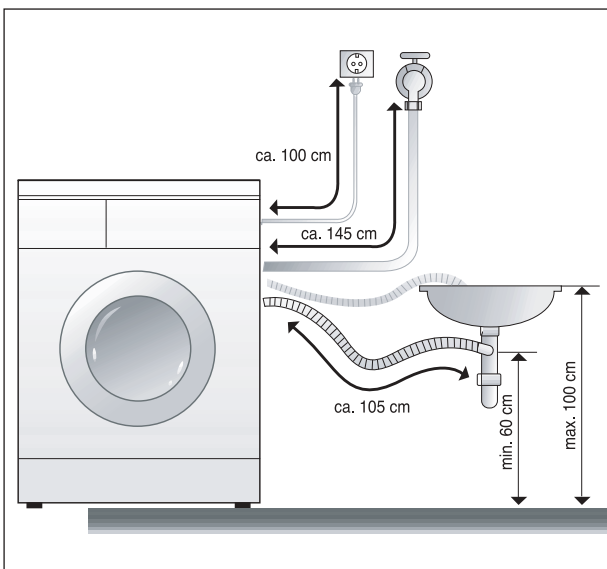

- The drain hose should not be placed **higher than 100cm above the floor.**
- Proper securing of the drain hose will **protect the floor from damage due to water leakage.**
- When the drain hose is too long, do **not force back in to the washer. This will cause abnormal noise.**

## ■ Level adjustment



1. The level adjustment of the washing machine prevents excessive noise and vibration. Install the washing machine on a solid and even floor surface, if possible, in a corner of the room.

**Note:** The wooden floor may cause excessive vibration.

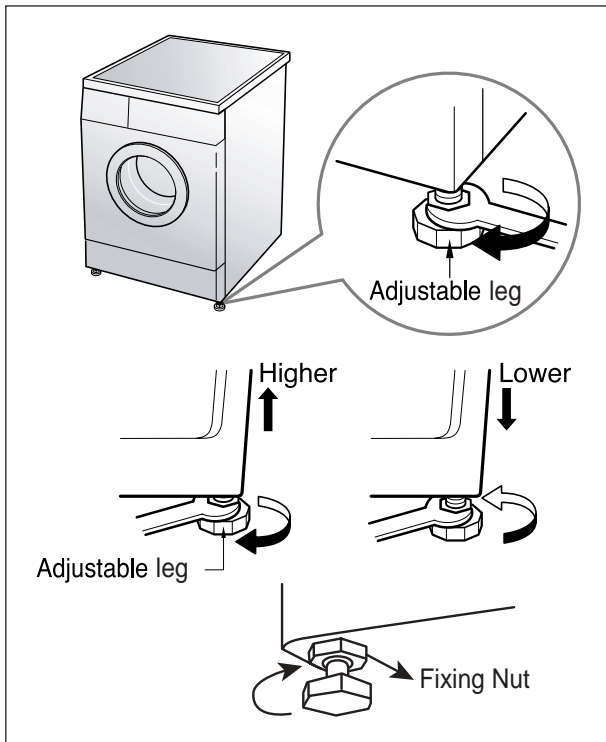

2. If the floor is uneven, adjust the adjustable leg as the following.  
(Do not insert pieces of wood etc. under legs.)
  - Please check whether there is any gap between four adjustable legs and the floor.
  - Turn adjustable legs by the enclosed spanner in order to adjust the level of the washing machine.
  - Make it sure that there is no swaying of the washing machine and check that the washing machine is even completely. (use a spirit level)
  - After the level adjustment is finished, turn fixing nuts up tightly so that the washing machine maintains the adjustment.

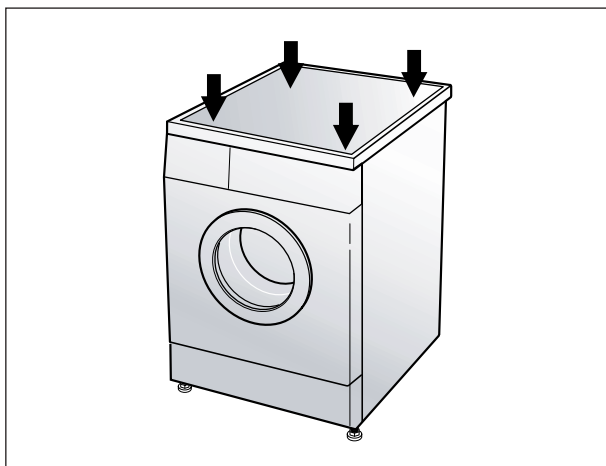

### ※ Diagonal Check

When pushing down the edges of the washing machine top plate diagonally, the machine should not move up and down at all.

(Please, check both of two directions)

If machine rocks when pushing the machine top plate diagonally, adjust legs again.

✿ Before cleaning the washer interior, unplug the electrical power cord avoid electrical shock hazards.

### ■ Cleaning your washer

#### 1. Exterior

Proper care of your washer can extend its life.

The outside of the machine can be cleaned with warm water and a neutral non abrasive household detergent.

Immediately wipe off any spills. Wipe with damp cloth.

Try not to hit surface with sharp objects.

- Do not use methylated spirits, diluents or similar products.

#### 2. Interior

Dry around the washer door opening, flexible gasket and door glass.

Run washer through a complete cycle using hot water.

Repeat process if necessary.

- Remove hard water deposits using only cleaners labeled as washer safe.

### ■ Cold condition

If the washer is stored in an area where freezing may occur or moved in freezing temperature, follow these instructions to prevent damage to the washer.

1. Turn off water supply tap.
2. Disconnect hoses from water supply and drain water from hoses.
3. Plug electrical cord into a properly grounded electrical outlet.
4. Add 1 gallon(3.8L) of nontoxic recreational vehicle(RV) antifreeze into empty wash drum.  
Close the door.
5. Set spin cycle and let washer spin for 1 minute to drain out all water.
6. Unplug electrical power cord, dry the drum interior, and close the door.
7. Remove detergent case and dry excessive water from the compartments.
8. Store washer in an upright position.
9. To remove antifreeze from washer after storage, run empty washer through a complete cycle using detergent.  
Do not add wash load.

## ■ Cleaning the water inlet filter

- "IE" error message will blink on the control panel when water does not enter the detergent drawer.
- If your water is very hard or contains traces of lime deposit, the water inlet filter may become clogged.
- It is therefore a good idea to clean it from time to time.

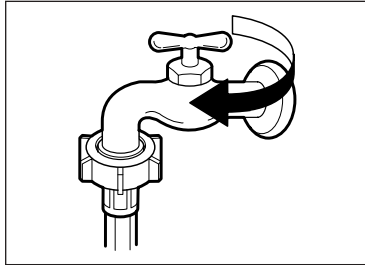

1. Turn off the water tap.

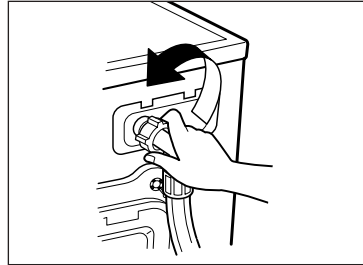

2. Unscrew the water inlet hose.

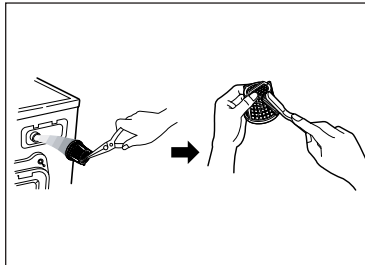

3. Clean the filter using a had bristle brush.

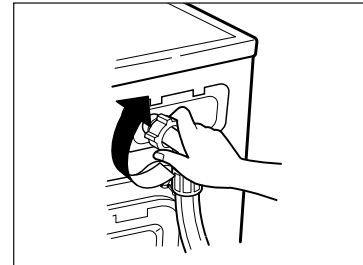

4. Tighten up the inlet hose.

## ■ Cleaning the drain pump filter

- The drain filter collects threads and small objects left in the laundry.
- Check regularly that the filter is clean to ensure smooth running of your machine.

**CAUTION** Be careful when draining if the water is hot.

1. Open the lower cover(①) by using a coin. Turn the cap hose(②) to pull out the hose. Pull out the hose maximally. (About 13~14cm.)

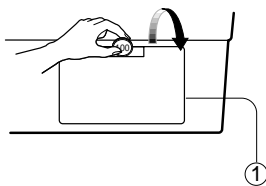

2. Unplug the cap hose(②), allowing the water to flow out. At this time use a vessel to prevent water flowing on to the floor. When water does not flow any more, turn the pump filter(③) open to the left.

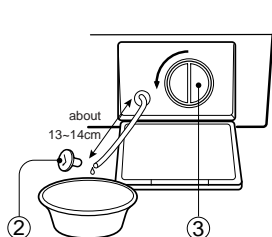

3. Remove any foreign material from the pump filter(③). After cleaning, turn the pump filter clockwise and insert the cap hose(②) to the original place. Close the lower cover.

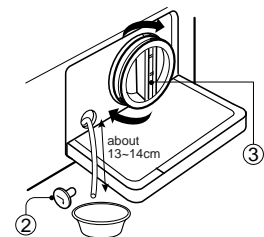



## ■ Cleaning the detergent case

- ✳ After a while detergents and fabric softeners leave a deposit in the detergent case.
- It should be cleaned from time to time with a jet of running water.
- If necessary it can be removed completely from the machine by pressing the catch downwards and by pulling it out.
- To facilitate cleaning, the upper part of the fabric softener compartment can be removed.

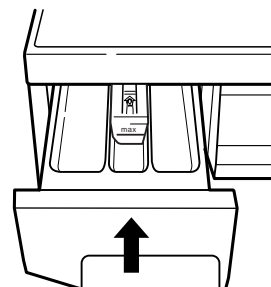
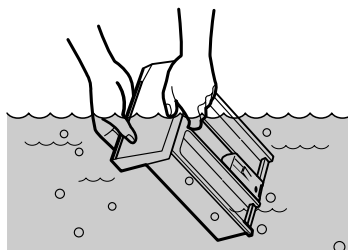
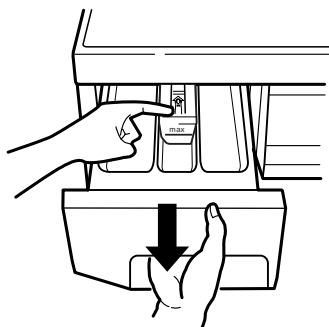

### Inlet box recess

- ✳ Detergent can also accumulate inside the recess which should be cleaned occasionally with an old toothbrush.
- Once you have finished cleaning, replace the detergent case and run a rinse cycle without laundry.

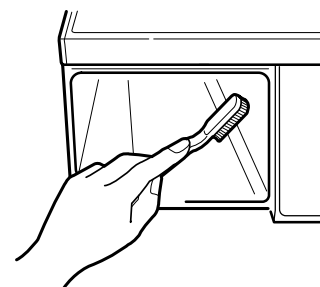

## ■ Cleaning the washing drum

- If you live in a hard water area, limescale may continuously build up in places where it cannot be seen and thus not easily removed.
- Over time the build up of scale clogs appliances, and if it is not kept in check these may have to be replaced.
- Although the washing drum is made of stainless steel, specks of rust can be caused by small metal articles (paper clips, safety pins) which have been left in the drum.
- The washing drum should be cleaned from time to time.
- If you use descaling agents, dyes or bleaches, make sure they are suitable for washing machine use.
- ✳ Descaler may contain chemicals that may damage part of your washing machine.
- ✳ Remove any spots with a stainless steel cleaning agent.
- ✳ Never use steel wool.

## 4. DIRECTION FOR DISASSEMBLY

### DOOR LOCK SWITCH

1) Open the door and remove the gasket clamp.



2) Remove the gasket from the front cabinet.



3) Remove two screws, and remove the door lock switch.



### HEATER AND THERMISTOR

1) Remove five screws on the COVER B and separate the COVER B from washing machine.



2) Remove the connectors of the HEATER.



3) Remove the nut using the 10mm hex wrench and remove the earth terminal from the HEATER.



4) Loosen the nut of the HEATER and pull out the HEATER.



## BLDC MOTOR

1) Remove the nut using the 17mm hex wrench.



2) Pull out the ROTOR.



3) Remove six screws using the 10mm hex wrench and connectors from the STATOR.



4) Separate the STATOR from the TUB.

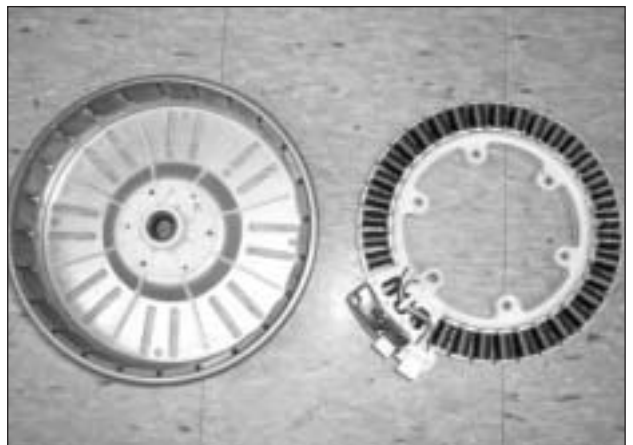

## DRAIN PUMP

1) Lay the right side of the washer on the floor, and remove the lower panel by pressing six snap fits.



2) Remove connectors.



3) Remove the screw, and remove the drain pump from the lower frame.



4) Remove the drain hose.



5) Remove the inner drain hose, and remove the drain pump.

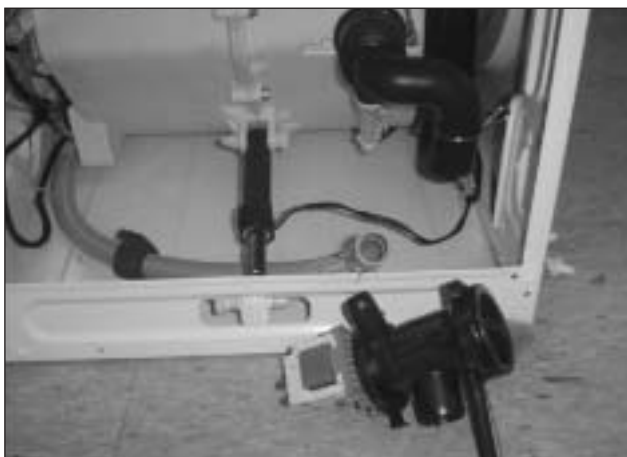

# 5. EXPLODE VIEW AND PARTS LIST

## ■ BOX INLET AS

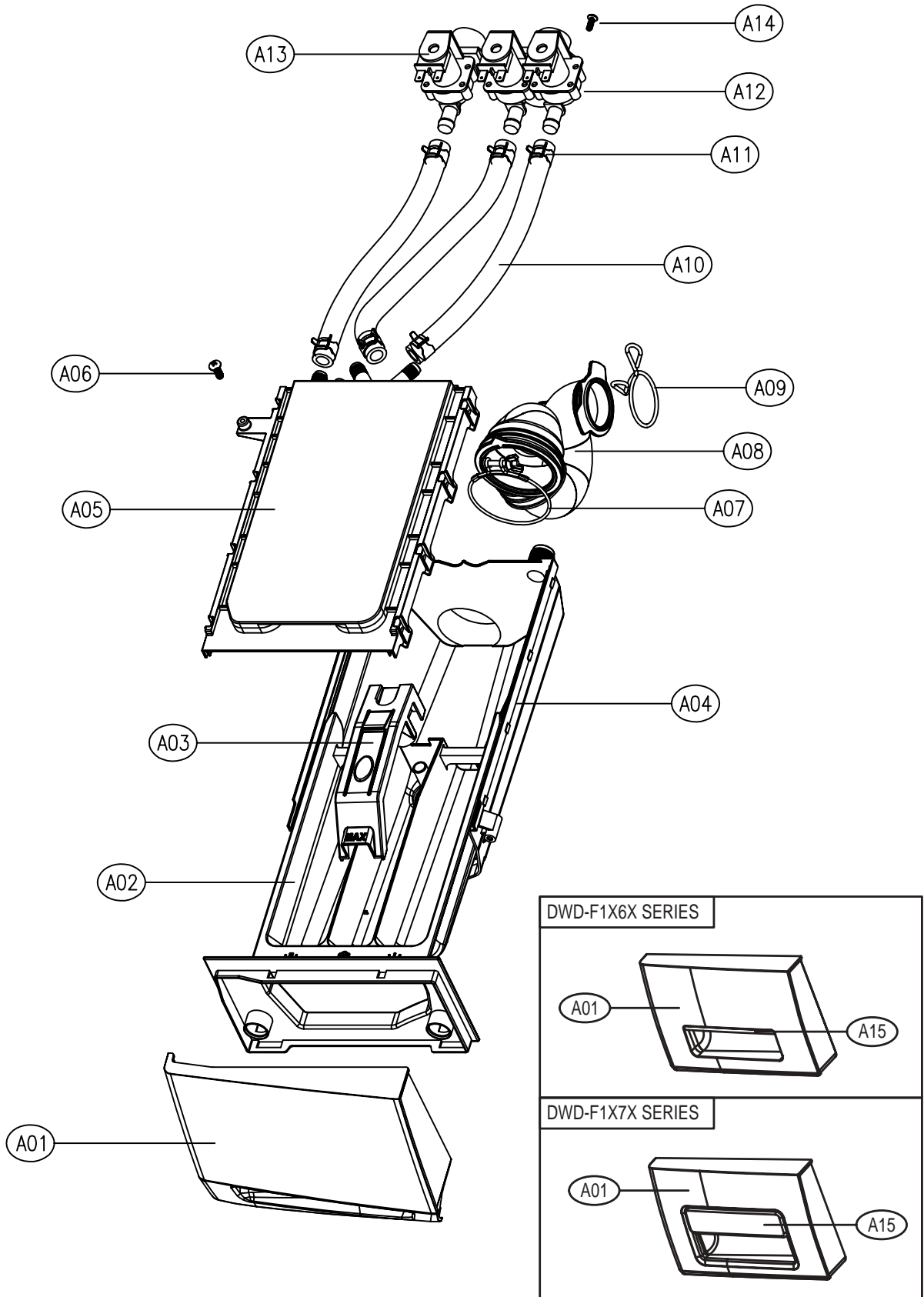

## ■ PANEL FRONT AS (DWD-FD145X SERIES)

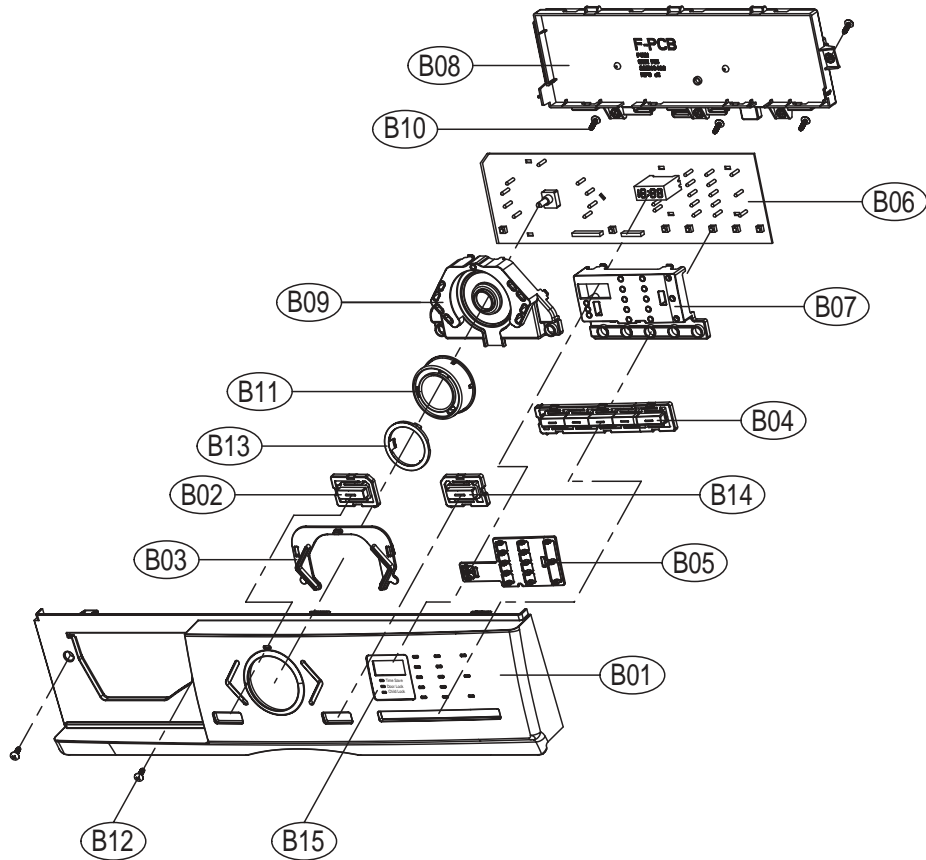

No.	PART NAME	PART CODE	SPECIFICATION	Q'TY	REMARK
B01	PANEL F	3614290100	HIPS, D-FU125'S	1	DWD-FD1451(2)
		3614290110	ABS D-FU1253'S		DWD-FD1453
B02	BUTTON POWER	3616644900	ABS	1	DWD-FD1451(2)
		3616644910	ABS + SPRAY		DWD-FD1453
B03	WINDOW COURSE	3615509500	ABS-TR	1	DWD-FD145X
B04	BUTTON FUNCTION	3616645100	ABS	1	DWD-FD1451(2)
		3616645110	ABS + SPRAY		DWD-FD1453
B05	WINDOW SELECTION	3615509600	ABS-TR	1	DWD-FD145X
B06	PCB AS	PRPSSWFE--	DWD-FD14'S, DONGSUH MOTOR	1	Refer to Detailed Part Code of PCB AS
		PRPSSWFF--	DWD-FD14'S, NEWMOTECH MOTOR	1	
B07	HOLDER LED FUNCTION	3613058800	HIPS	1	DWD-FD145X
B08	CASE PCB	3611149400	HIPS	1	DWD-FD145X
B09	HOLDER LED COURSE	3613058700	HIPS	1	DWD-FD145X
B10	SCREW TAPPING	7122401611	T2S TRS 4x16 MFZN	4	
B11	BUTTON DIAL	3616644800	ABS	1	DWD-FD1451(2)
		3616644810	ABS + SPRAY		DWD-FD1453
B12	SCREW TAPPING	7122401608	T2S TRS 4x16 SUS	2	
B13	DECORATOR BUTTON DIAL	3611696400	ABS, GILDING	1	DWD-FD145X
B14	BUTTON START	3616645000	ABS	1	DWD-FD1451(2)
		3616645010	ABS + SPRAY		DWD-FD1453
B15	DECORATOR FILM	3611689900	P.C FILM	1	DWD-FD145X



## ■ Detailed Part Code of PCB AS (DONGSUH)

No.	PART NAME	PART CODE	SPECIFICATION	Q'TY	REMARK
B06	PCB AS	PRPSSWFE51	RENE, FAIR, NON-EC, COLD, HOT, BUBBLE, 1W	1	1st PANEL (DWD- FD141X SERIES)
		PRPSSWFE52	RENE, FAIR, NON-EC, COLD, HOT, NON-BUBBLE, 1W		
		PRPSSWFE53	RENE, FAIR, NON-EC, COLD, BUBBLE, 1W		
		PRPSSWFE54	RENE, FAIR, NON-EC, COLD, NON-BUBBLE, 1W		
		PRPSSWFE55	RENE, FAIR, EC, COLD, HOT, BUBBLE, 1W		
		PRPSSWFE56	RENE, FAIR, EC, COLD, HOT, NON-BUBBLE, 1W		
		PRPSSWFE57	RENE, FAIR, EC, COLD, BUBBLE, 1W		
		PRPSSWFE58	RENE, FAIR, EC, COLD, NON-BUBBLE, 1W		
		PRPSSWFE5A	RENE, FAIR, NON-EC, COLD, HOT, BUBBLE, NON-1W		
		PRPSSWFE5B	RENE, FAIR, NON-EC, COLD, HOT, NON-BUBBLE, NON-1W		
		PRPSSWFE5C	RENE, FAIR, NON-EC, COLD, BUBBLE, NON-1W		
		PRPSSWFE5D	RENE, FAIR, NON-EC, COLD, NON-BUBBLE, NON-1W		
		PRPSSWFE5E	RENE, FAIR, EC, COLD, HOT, BUBBLE, NON-1W		
		PRPSSWFE5F	RENE, FAIR, EC, COLD, HOT, NON-BUBBLE, NON-1W		
		PRPSSWFE5G	RENE, FAIR, EC, COLD, BUBBLE, NON-1W		
		PRPSSWFE5H	RENE, FAIR, EC, COLD, NON-BUBBLE, NON-1W		
		PRPSSWFE61	RENE, FAIR,, NON-EC, COLD, HOT, BUBBLE, 1W		2nd PANEL (DWD- FD142X SERIES)
		PRPSSWFE62	RENE, FAIR, NON-EC, COLD, HOT, NON-BUBBLE, 1W		
		PRPSSWFE69	RENE, FAIR, NON-EC OPTION, COLD OPTION, BUBBLE OPTION, 1W		
		PRPSSWFE64	RENE, FAIR, NON-EC, COLD, NON-BUBBLE, 1W		
		PRPSSWFE65	RENE, FAIR, EC, COLD, HOT, BUBBLE, 1W		
		PRPSSWFE66	RENE, FAIR, EC, COLD, HOT, NON-BUBBLE, 1W		
		PRPSSWFE67	RENE, FAIR, EC, COLD, BUBBLE, 1W		
		PRPSSWFE68	RENE, FAIR, EC, COLD, NON-BUBBLE, 1W		
		PRPSSWFE6A	RENE, FAIR,, NON-EC, COLD, HOT, BUBBLE, NON-1W		
		PRPSSWFE6B	RENE, FAIR, NON-EC, COLD, HOT, NON-BUBBLE, NON-1W		
		PRPSSWFE6C	RENE, FAIR, NON-EC OPTION, COLD OPTION, BUBBLE OPTION, NON-1W		
		PRPSSWFE6D	RENE, FAIR, NON-EC, COLD, NON-BUBBLE, NON-1W		
		PRPSSWFE6E	RENE, FAIR, EC, COLD, HOT, BUBBLE, NON-1W		
		PRPSSWFE6F	RENE, FAIR, EC, COLD, HOT, NON-BUBBLE, NON-1W		
		PRPSSWFE6G	RENE, FAIR, EC, COLD, BUBBLE, NON-1W		
		PRPSSWFE6H	RENE, FAIR, EC, COLD, NON-BUBBLE, NON-1W		3rd PANEL (DWD- FD143X SERIES)
		PRPSSWFE71	RENE, FAIR,, NON-EC, COLD, HOT, BUBBLE, 1W		
		PRPSSWFE72	RENE, FAIR, NON-EC, COLD, HOT, NON-BUBBLE, 1W		
		PRPSSWFE73	RENE, FAIR, NON-EC OPTION, COLD OPTION, BUBBLE OPTION, 1W		
PRPSSWFE74	RENE, FAIR, NON-EC, COLD, NON-BUBBLE, 1W				
PRPSSWFE75	RENE, FAIR, EC, COLD, HOT, BUBBLE, 1W				
PRPSSWFE76	RENE, FAIR, EC, COLD, HOT, NON-BUBBLE, 1W				
PRPSSWFE77	RENE, FAIR, EC, COLD, BUBBLE, 1W				
PRPSSWFE78	RENE, FAIR, EC, COLD, NON-BUBBLE, 1W				
PRPSSWFE7A	RENE, FAIR,, NON-EC, COLD, HOT, BUBBLE, NON-1W				
PRPSSWFE7B	RENE, FAIR, NON-EC, COLD, HOT, NON-BUBBLE, NON-1W				
PRPSSWFE7C	RENE, FAIR, NON-EC OPTION, COLD OPTION, BUBBLE OPTION, NON-1W				
PRPSSWFE7D	RENE, FAIR, NON-EC, COLD, NON-BUBBLE, NON-1W				

No.	PART NAME	PART CODE	SPECIFICATION	Q'TY	REMARK
B06	PCB AS	PRPSSWFE7E	RENE, FAIR, EC, COLD, HOT, BUBBLE, NON-1W	1	3rd PANEL (DWD- FD143X SERIES)
		PRPSSWFE7F	RENE, FAIR, EC, COLD, HOT, NON-BUBBLE, NON-1W		
		PRPSSWFE7G	RENE, FAIR, EC, COLD, BUBBLE, NON-1W		
		PRPSSWFE7H	RENE, FAIR, EC, COLD, NON-BUBBLE, NON-1W		
		PRPSSWFE81	RENE, FAIR,, NON-EC, COLD, HOT, BUBBLE, 1W		
		PRPSSWFE82	RENE, FAIR, NON-EC, COLD, HOT, NON-BUBBLE, 1W		
		PRPSSWFE83	RENE, FAIR, NON-EC OPTION, COLD OPTION, BUBBLE OPTION, 1W		4th PANEL (DWD- FD144X SERIES)
		PRPSSWFE84	RENE, FAIR, NON-EC, COLD, NON-BUBBLE, 1W		
		PRPSSWFE85	RENE, FAIR, EC, COLD, HOT, BUBBLE, 1W		
		PRPSSWFE86	RENE, FAIR, EC, COLD, HOT, NON-BUBBLE, 1W		
		PRPSSWFE87	RENE, FAIR, EC, COLD, BUBBLE, 1W		
		PRPSSWFE88	RENE, FAIR, EC, COLD, NON-BUBBLE, 1W		
		PRPSSWFE8A	RENE, FAIR,, NON-EC, COLD, HOT, BUBBLE, NON-1W		
		PRPSSWFE8B	RENE, FAIR, NON-EC, COLD, HOT, NON-BUBBLE, NON-1W		
		PRPSSWFE8C	RENE, FAIR, NON-EC OPTION, COLD OPTION, BUBBLE OPTION, NON-1W		
		PRPSSWFE8D	RENE, FAIR, NON-EC, COLD, NON-BUBBLE, NON-1W		
		PRPSSWFE8E	RENE, FAIR, EC, COLD, HOT, BUBBLE, NON-1W		
		PRPSSWFE8F	RENE, FAIR, EC, COLD, HOT, NON-BUBBLE, NON-1W		
PRPSSWFE8G	RENE, FAIR, EC, COLD, BUBBLE, NON-1W				
PRPSSWFE8H	RENE, FAIR, EC, COLD, NON-BUBBLE, NON-1W				
		PRPSSWFE41	RENESAS, NON-EC OPTION, COLD, HOT OPTION, BUBBLE OPTION, 1W	1	5th PANEL (DWD- FD145X SERIES)
		PRPSSWFE42	RENESAS, NON-EC OPTION, COLD, HOT OPTION, NON-BUBBLE OPTION, 1W		
		PRPSSWFE43	RENESAS, NON-EC OPTION, COLD OPTION, BUBBLE OPTION, 1W		
		PRPSSWFE44	RENESAS, NON-EC OPTION, COLD OPTION, NON-BUBBLE OPTION, 1W		
		PRPSSWFE45	RENESAS, EC OPTION, COLD, HOT OPTION, BUBBLE OPTION, 1W		
		PRPSSWFE46	RENESAS, EC OPTION, COLD, HOT OPTION, NON-BUBBLE OPTION, 1W		
		PRPSSWFE47	RENESAS, EC OPTION, COLD OPTION, BUBBLE OPTION, 1W		
		PRPSSWFE48	RENESAS, EC OPTION, COLD OPTION, NON-BUBBLE OPTION, 1W		
		PRPSSWFE4A	RENESAS, NON-EC OPTION, COLD, HOT OPTION, BUBBLE OPTION, NON-1W		
		PRPSSWFE4B	RENESAS, NON-EC OPTION, COLD, HOT OPTION, NON-BUBBLE OPTION, NON-1W		
		PRPSSWFE4C	RENESAS, NON-EC OPTION, COLD OPTION, BUBBLE OPTION, NON-1W		
		PRPSSWFE4D	RENESAS, NON-EC OPTION, COLD OPTION, NON-BUBBLE OPTION, NON-1W		
		PRPSSWFE4E	RENESAS, EC OPTION, COLD, HOT OPTION, BUBBLE OPTION, NON-1W		
		PRPSSWFE4F	RENESAS, EC OPTION, COLD, HOT OPTION, NON-BUBBLE OPTION, NON-1W		
		PRPSSWFE4G	RENESAS, EC OPTION, COLD OPTION, BUBBLE OPTION, NON-1W		
		PRPSSWFE4H	RENESAS, EC OPTION, COLD OPTION, NON-BUBBLE OPTION, NON-1W		



## ■ Detailed Part Code of PCB AS (NEWMOTECH)

No.	PART NAME	PART CODE	SPECIFICATION	Q'TY	REMARK
B06	PCB AS	PRPSSWFF51	D-FD141,RENE,FAIR,NON-EC,HOT,BB,1W,N/M	1	1st PANEL (DWD-FD141X SERIES)
		PRPSSWFF52	D-FD141,RENE,FAIR,NON-EC,HOT,NON-BB,1W,N/M		
		PRPSSWFF53	D-FD141,RENE,FAIR,NON-EC,COLD,BB,1W,N/M		
		PRPSSWFF54	D-FD141,RENE,FAIR,NON-EC,COLD,NON-BB,1W,N/M		
		PRPSSWFF55	D-FD141,RENE,FAIR,EC,HOT,BB,1W,N/M		
		PRPSSWFF56	D-FD141,RENE,FAIR,EC,HOT,NON-BB,1W,N/M		
		PRPSSWFF57	D-FD141,RENE,FAIR,EC,COLD,BB,1W,N/M		
		PRPSSWFF58	D-FD141,RENE,FAIR,EC,COLD,NON-BB,1W,N/M		
		PRPSSWFF5A	D-FD141,RENE,FAIR,NON-EC,HOT,BB,NON-1W,N/M		
		PRPSSWFF5B	D-FD141,RENE,FAIR,NON-EC,HOT,NON-BB,NON-1W,N/M		
		PRPSSWFF5C	D-FD141,RENE,FAIR,NON-EC,COLD,BB,NON-1W,N/M		
		PRPSSWFF5D	D-FD141,RENE,FAIR,NON-EC,COLD,NON-BB,NON-1W,N/M		
		PRPSSWFF5E	D-FD141,RENE,FAIR,EC,HOT,BB,NON-1W,N/M		
		PRPSSWFF5F	D-FD141,RENE,FAIR,EC,HOT,NON-BB,NON-1W,N/M		
		PRPSSWFF5G	D-FD141,RENE,FAIR,EC,COLD,BB,NON-1W,N/M		
		PRPSSWFF5H	D-FD141,RENE,FAIR,EC,COLD,NON-BB,NON-1W,N/M		
		PRPSSWFF61	D-FD142,RENE,FAIR,NON-EC,HOT,BB,1W,N/M		
		PRPSSWFF62	D-FD142,RENE,FAIR,NON-EC,HOT,NON-BB,1W,N/M		
		PRPSSWFF63	D-FD142,RENE,FAIR,NON-EC,COLD,BB,1W,N/M		
		PRPSSWFF64	D-FD142,RENE,FAIR,NON-EC,COLD,NON-BB,1W,N/M		
		PRPSSWFF65	D-FD142,RENE,FAIR,EC,HOT,BB,1W,N/M		
		PRPSSWFF66	D-FD142,RENE,FAIR,EC,HOT,NON-BB,1W,N/M		
		PRPSSWFF67	D-FD142,RENE,FAIR,EC,COLD,BB,1W,N/M		
		PRPSSWFF68	D-FD142,RENE,FAIR,EC,COLD,NON-BB,1W,N/M		
		PRPSSWFF6A	D-FD142,RENE,FAIR,NON-EC,HOT,BB,NON-1W,N/M		
		PRPSSWFF6B	D-FD142,RENE,FAIR,NON-EC,HOT,NON-BB,NON-1W,N/M		
		PRPSSWFF6C	D-FD142,RENE,FAIR,NON-EC,COLD,BB,NON-1W,N/M		
		PRPSSWFF6D	D-FD142,RENE,FAIR,NON-EC,COLD,NON-BB,NON-1W,N/M		
		PRPSSWFF6E	D-FD142,RENE,FAIR,EC,HOT,BB,NON-1W,N/M		
		PRPSSWFF6F	D-FD142,RENE,FAIR,EC,HOT,NON-BB,NON-1W,N/M		
		PRPSSWFF6G	D-FD142,RENE,FAIR,EC,COLD,BB,NON-1W,N/M		
		PRPSSWFF6H	D-FD142,RENE,FAIR,EC,COLD,NON-BB,NON-1W,N/M		
		PRPSSWFF71	D-FD143,RENE,FAIR,NON-EC,HOT,BB,1W,N/M		3rd PANEL (DWD-FD143X SERIES)
		PRPSSWFF72	D-FD143,RENE,FAIR,NON-EC,HOT,NON-BB,1W,N/M		
		PRPSSWFF73	D-FD143,RENE,FAIR,NON-EC,COLD,BB,1W,N/M		
		PRPSSWFF74	D-FD143,RENE,FAIR,NON-EC,COLD,NON-BB,1W,N/M		
		PRPSSWFF75	D-FD143,RENE,FAIR,EC,HOT,BB,1W,N/M		
		PRPSSWFF76	D-FD143,RENE,FAIR,EC,HOT,NON-BB,1W,N/M		
		PRPSSWFF77	D-FD143,RENE,FAIR,EC,COLD,BB,1W,N/M		
		PRPSSWFF78	D-FD143,RENE,FAIR,EC,COLD,NON-BB,1W,N/M		
		PRPSSWFF7A	D-FD143,RENE,FAIR,NON-EC,HOT,BB,NON-1W,N/M		
PRPSSWFF7B	D-FD143,RENE,FAIR,NON-EC,HOT,NON-BB,NON-1W,N/M				
PRPSSWFF7C	D-FD143,RENE,FAIR,NON-EC,COLD,BB,NON-1W,N/M				
PRPSSWFF7D	D-FD143,RENE,FAIR,NON-EC,COLD,NON-BB,NON-1W,N/M				

No.	PART NAME	PART CODE	SPECIFICATION	Q'TY	REMARK
B06	PCB AS	PRPSSWFF7E	D-FD143,RENE,FAIR,EC,HOT,BB,NON-1W,N/M	1	3rd PANEL (DWD- FD143X SERIES)
		PRPSSWFF7F	D-FD143,RENE,FAIR,EC,HOT,NON-BB,NON-1W,N/M		
		PRPSSWFF7G	D-FD143,RENE,FAIR,EC,COLD,BB,NON-1W,N/M		
		PRPSSWFF7H	D-FD143,RENE,FAIR,EC,COLD,NON-BB,NON-1W,N/M		
		PRPSSWFF81	D-FD144,RENE,FAIR,NON-EC,HOT,BB,1W,N/M		
		PRPSSWFF82	D-FD144,RENE,FAIR,NON-EC,HOT,NON-BB,1W,N/M		
		PRPSSWFF83	D-FD144,RENE,FAIR,NON-EC,COLD,BB,1W,N/M		
		PRPSSWFF84	D-FD144,RENE,FAIR,NON-EC,COLD,NON-BB,1W,N/M		
		PRPSSWFF85	D-FD144,RENE,FAIR,EC,HOT,BB,1W,N/M		
		PRPSSWFF86	D-FD144,RENE,FAIR,EC,HOT,NON-BB,1W,N/M		
		PRPSSWFF87	D-FD144,RENE,FAIR,EC,COLD,BB,1W,N/M		4th PANEL (DWD- FD144X SERIES)
		PRPSSWFF88	D-FD144,RENE,FAIR,EC,COLD,NON-BB,1W,N/M		
		PRPSSWFF8A	D-FD144,RENE,FAIR,NON-EC,HOT,BB,NON-1W,N/M		
		PRPSSWFF8B	D-FD144,RENE,FAIR,NON-EC,HOT,NON-BB,NON-1W,N/M		
		PRPSSWFF8C	D-FD144,RENE,FAIR,NON-EC,COLD,BB,NON-1W,N/M		
		PRPSSWFF8D	D-FD144,RENE,FAIR,NON-EC,COLD,NON-BB,NON-1W,N/M		
		PRPSSWFF8E	D-FD144,RENE,FAIR,EC,HOT,BB,NON-1W,N/M		
		PRPSSWFF8F	D-FD144,RENE,FAIR,EC,HOT,NON-BB,NON-1W,N/M		
		PRPSSWFF8G	D-FD144,RENE,FAIR,EC,COLD,BB,NON-1W,N/M		
		PRPSSWFF8H	D-FD144,RENE,FAIR,EC,COLD,NON-BB,NON-1W,N/M		
		PRPSSWFF41	D-FD145,RENE,FAIR,NON-EC,HOT,BB,1W,N/M	1	5th PANEL (DWD- FD145X SERIES)
		PRPSSWFF42	D-FD145,RENE,FAIR,NON-EC,HOT,NON-BB,1W,N/M		
		PRPSSWFF43	D-FD145,RENE,FAIR,NON-EC,COLD,BB,1W,N/M		
		PRPSSWFF44	D-FD145,RENE,FAIR,NON-EC,COLD,NON-BB,1W,N/M		
		PRPSSWFF45	D-FD145,RENE,FAIR,EC,HOT,BB,1W,N/M		
		PRPSSWFF46	D-FD145,RENE,FAIR,EC,HOT,NON-BB,1W,N/M		
		PRPSSWFF47	D-FD145,RENE,FAIR,EC,COLD,BB,1W,N/M		
		PRPSSWFF48	D-FD145,RENE,FAIR,EC,COLD,NON-BB,1W,N/M		
		PRPSSWFF4A	D-FD145,RENE,FAIR,NON-EC,HOT,BB,NON-1W,N/M		
		PRPSSWFF4B	D-FD145,RENE,FAIR,NON-EC,HOT,NON-BB,NON-1W,N/M		
		PRPSSWFF4C	D-FD145,RENE,FAIR,NON-EC,COLD,BB,NON-1W,N/M		
		PRPSSWFF4D	D-FD145,RENE,FAIR,NON-EC,COLD,NON-BB,NON-1W,N/M		
		PRPSSWFF4E	D-FD145,RENE,FAIR,EC,HOT,BB,NON-1W,N/M		
		PRPSSWFF4F	D-FD145,RENE,FAIR,EC,HOT,NON-BB,NON-1W,N/M		
		PRPSSWFF4G	D-FD145,RENE,FAIR,EC,COLD,BB,NON-1W,N/M		
		PRPSSWFF4H	D-FD145,RENE,FAIR,EC,COLD,NON-BB,NON-1W,N/M		

## ■ CABINET FRONT AS

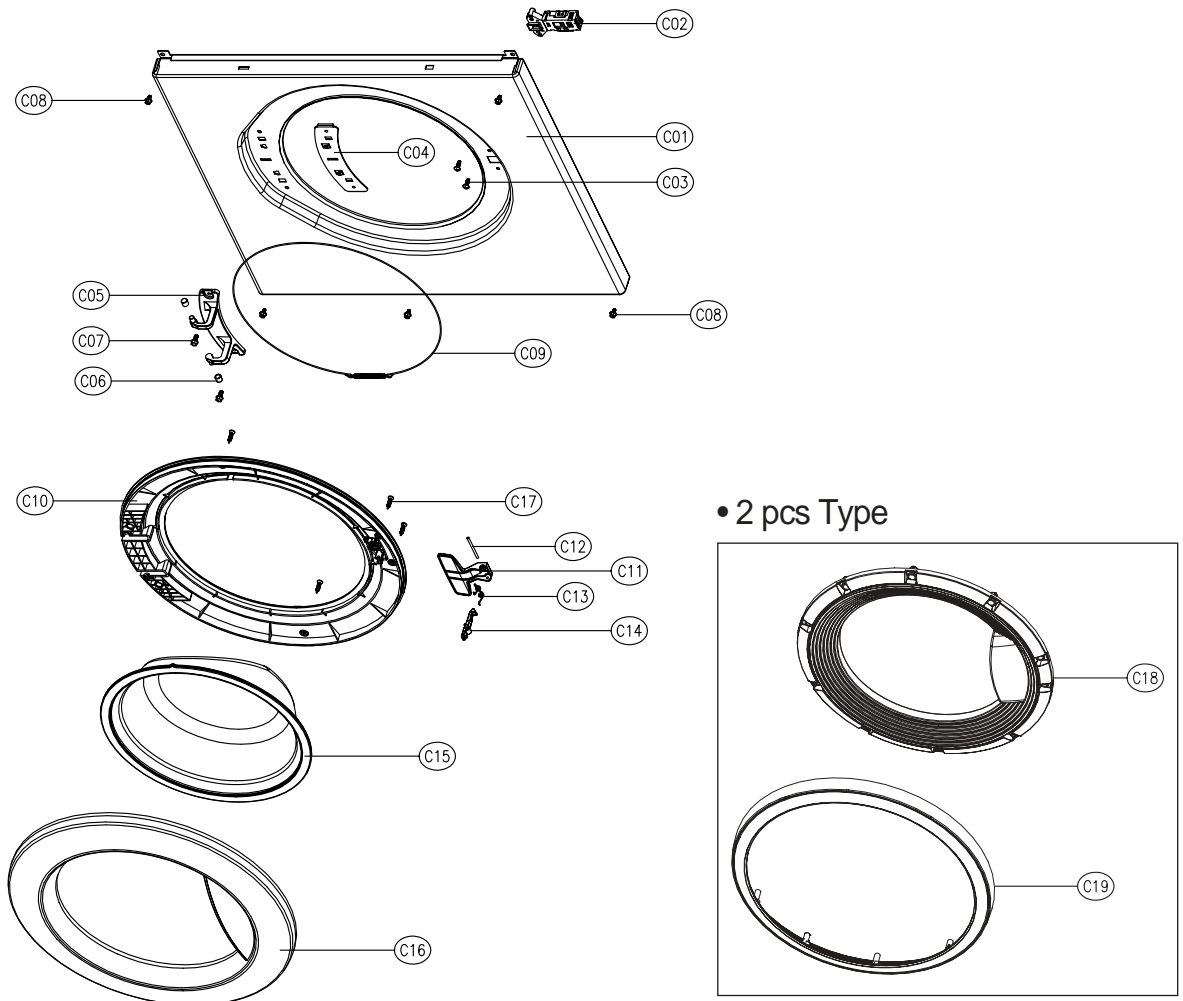

No.	PART NAME	PART CODE	SPECIFICATION	Q'TY	REMARK
C01	CABINET *F	3610811220	SECD 0.7T	1	DWD-FD14X1(2) DWD-FD14X3
		3610811210	PCM, SGCC 0.8T, SILVER		
C02	SWITCH DOOR LOCK	3619047100	DL-LC BITRON_3P 250V 16A BI-METAL	1	
C03	SCREW TAPPING	7122401208	T2S TRS 4X12 SUS	2	
C04	PLATE HINGE SUPPORT	3614531900	SGCC T1.6	0	No use
C05	HINGE DOOR	3612902800	ALDC	1	
C06	CAP HINGE DOOR	3610916500	POM	2	
C07	SCREW TAPPING	3616051229	F/L BOLT(SE) 5*12 SUS	2	
C08	SCREW TAPPING	3616029950	TTS"S" HEX F/L 4*8	6	
C09	CLAMP DOOR AS	3611204810	HSW3, D=1.4 GS	1	
C10	FRAME DOOR *I	3612205200	PP	1	
C11	HANDLE DOOR	3612608600	ABS	1	
C12	PIN HANDLE	3618200200	SUS304, D3, L48	1	
C13	SPRING HOOK	3615114600	SUS D1.4	1	
C14	HOOK DOOR	3613100700	ZNDC	1	
C15	DOOR GLASS	361A110700	GLASS PI300	1	
C16	FRAME DOOR *O	3612205102	HIPS D-F'S	1	DWD-FD14X1 DWD-FD14X2(3)
		3612205120	CR3		
C17	SCREW TAPPING	7115402029	T1S FLT 4*20 SUS	6	
C18	FRAME DOOR O	3612211900	D-F'S, 2 PCS TYPE, ABS, BLACK	1	2 pcs type(option)
		3612211910	D-F'S, 2 PCS TYPE, HIPS, WHITE		
C19	DECO DOOR O	3612212000	D-F'SERIES 6&7TH , ABS	1	

■ TUB ASS'Y

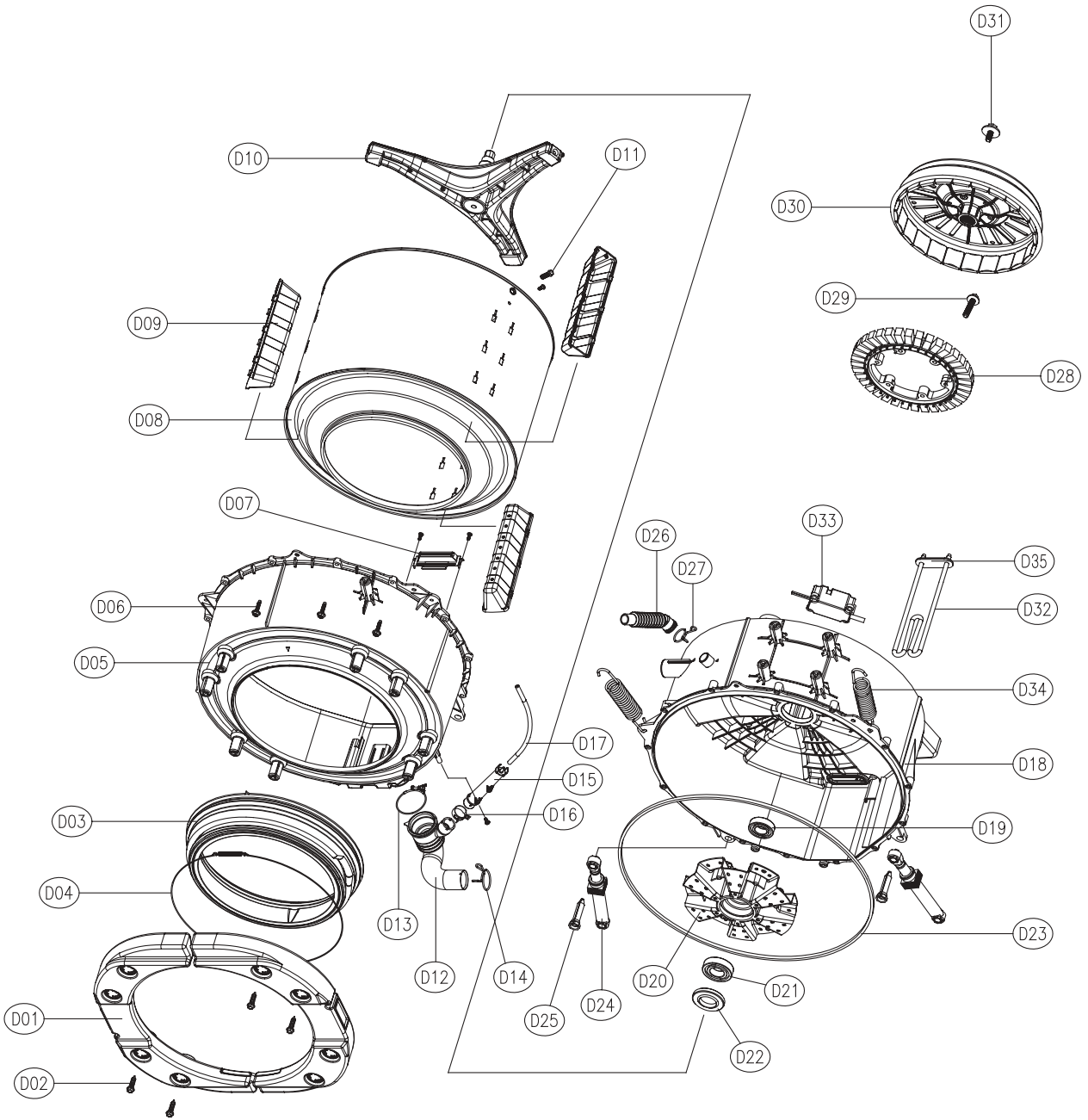

No.	PART NAME	PART CODE	SPECIFICATION	Q'TY	REMARK
D01	BALANCER WEIGHT F L/R	3616106320	FRONT, 5.5kg	2	
D02	SPECIAL SCREW(BALANCER)	3616029400	SWCH 8.5X30	8	
D03	GASKET	3612321400	EPDM	1	
D04	CLAMP GASKET AS	3611204520	HSW3,GS	1	
D05	TUB *F	3618821010	FRPP FH7304GM	1	
D06	SPECIAL SCREW(TUB)	3616029800	SWCH 6.5X30	14	
D07	FIXTURE HEATER	3612007300	SUS 0.7T 440°ø45	1	
D08	DRUM SUB AS	3617004002	SUS 0.5T	1	
D09	LIFTER WASH	361A400400	PP	3	OPTION
		361A400410	NANO		
D10	SPIDER AS	361A300510	ALDC+SM45C	1	
D11	SPECIAL SCREW(SPIDER)	3616029500	SUS430 8x25	3	
D12	HOSE DRAIN	3613267300	EPDM	1	
D13	CLAMP AS	3611203210	ID=60,WIRE+GUIDE+BOLT+NUT	1	
D14	CLAMP HOSE I	3611201401	HSW3, D2.6, MFZN, D=38	1	
D15	AIR TRAP	361A500101	PP	1	
D16	CLAMP HOSE	3611204700	D26	1	
D17	HOSE AIR	3613268600	ID=4, OD=8, L=700	1	
D18	TUB REAR AS	36100E2U10	D-FD14	1	
D18-1	TUB REAR	3618821110	FRPP FH7304GM 1	1	
D18-2	BEARING HOUSING	3616303321	ALDC M8 TAP D-FD'S DOMESTIC	1	
D19	BEARING OUTER	3616303200	6205Z FAG	1	
D20	BEARING HOUSING	3616303321	ALDC M8 TAP D-FD'S DOMESTIC	1	
D21	BEARING INNER	3616303100	6206Z FAG	1	
D22	WATER SEAL	361A600100	NBR	1	
D23	GASKET TUB (SEALING TUB)	3612321601	EPDM L=1600(-0,+10)	1	
D24	DAMPER FRICTION	361A700120	120N, AKS, ST=170-160, DL=197.5	2	
D25	DAMPER PIN	361A700200	AKS, D=14.5	2	
D26	HOSE VENT	3613267100	EPDM	1	
D27	CLAMP HOSE	3611204700	D26, wire-type	1	
D28	UNIT STATOR BLDC	36189L4820	AL-16T 36SLOT 2SNESOR	1	DONGSU
		36189L621A	AL,DON1000W 18T 36POLE,NMT,PBT	1	NEWMOTECH
		36189L621E	AL,DON1000W 18T 36POLE,ENTEK,NMT,PBT	1	NEWMOTECH
D29	SPECIAL BOLT AS	3616029920	SWCH M8+SILOCK, 35MM	6	DONGSU
		3616029910	SWCH M8+SILOCK,49MM	6	NEWMOTECH
D30	UNIT ROTOR BLDC	36189L4910	MAGENT24 SERRATION	1	DONGSU
		36189I6310	DON1000W SR-FERRITE12, 18T, NMT	1	NEWMOTECH
D32	HEATER WASH	3612802400	220V 2KW.1R0A721001.RW8TF.IRCA	1	DWD-FD'S(220V)
		3612802410	230V 2KW.1R0A721002.RW8TF.IRCA	1	DWD-FD'S(230V)
		3612802420	240V 2KW.1R0A721003.RW8TF.IRCA 1	1	DWD-FD'S(240V)
		3612802430	110V 1KW.1R0A721004.RW8TF.IRCA	1	DWD-F'S(110V)
		3612802440	120V 1KW.1R0A721005.RW8TF1PE.IRCA	1	DWD-FD'S(120-127V)
		3612803700	230V 2000W.1R5A721002.IRCA FUSE 2EA	1	DWD-F'S(230V), VDE
D33	UNIT BUBBLE PUMP AS	36189L4120	220-240V DBK-240DB RP CHSHION	1	OPTION(220-240)
		36189L4G10	100-130 DBK-115DB RP-CUSH		OPTION(100-130)
D34	SPRING SUSPENSION	3615115310	D3.2, L164	2	
D35	THERMISTOR WASH	361AAAAB10	R25=1.704kΩ R80=11.981kΩ	1	

# ■ CABINET AS

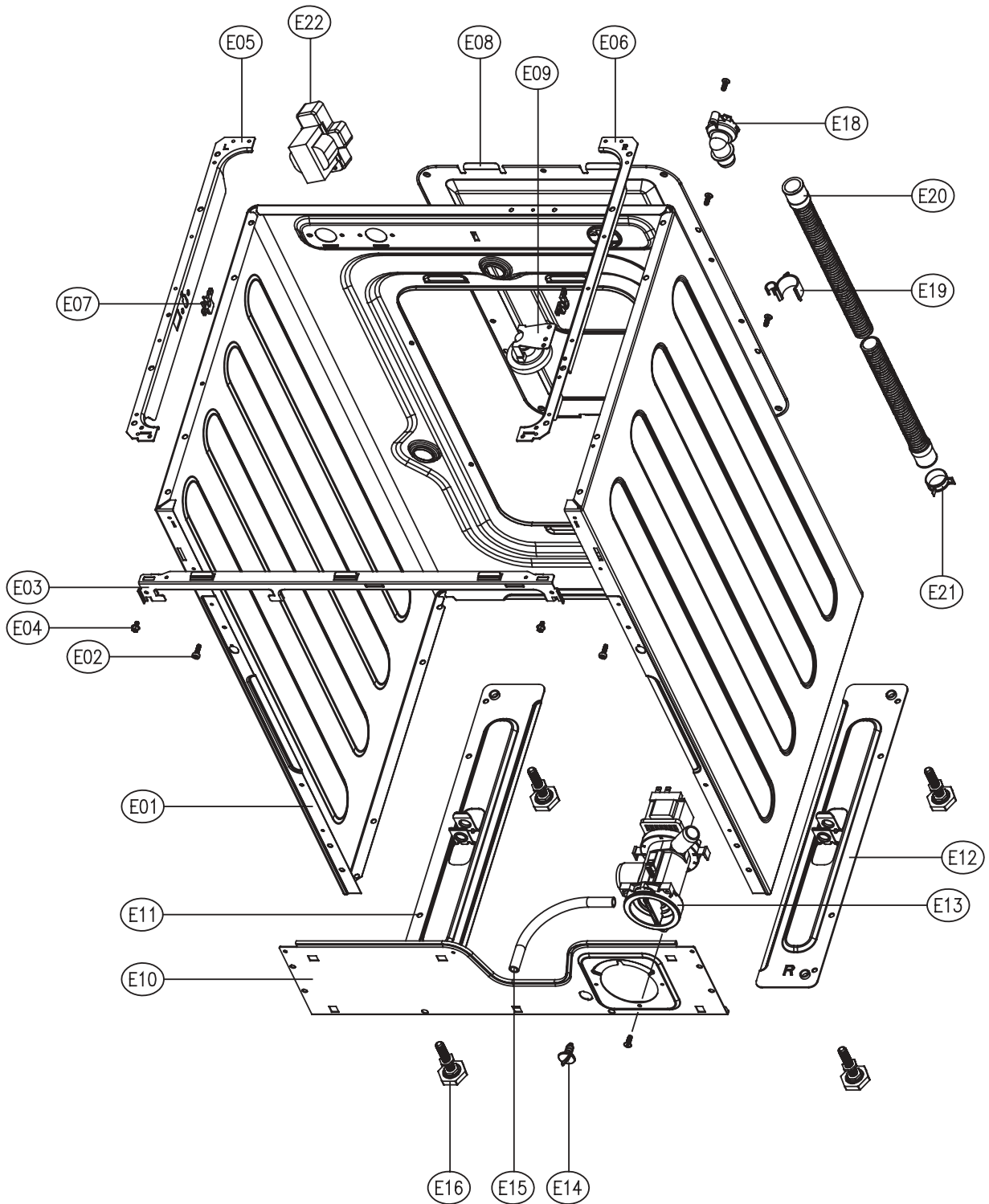



No.	PART NAME	PART CODE	SPECIFICATION	Q'TY	REMARK
E01	CABINET	3610811101	SGCC(GI), 0.7TX825.7X1630.8	1	DWD-FD'S
E02	SPECIAL SCREW	3616029100	M4x12.5, MACHINE	2	
E03	FRAME UPPER	3612205801	SGCC T1.0 55X580	1	
E04	SCREW TAPPING	3616029950	TTS"S" HEX F/L 4X8	4	
E05	FRAME TOP *L	3612205601	SGCC T1.4 52x500	1	
E06	FRAME TOP *R	3612205701	SGCC T1.4 52x500	1	
E07	STOPPER SPRING	3615202200	POM	2	
E08	COVER *B	3611427100	PP	1	
E09	SENSOR PRESSURE	3614825300	5V DRUM DL-DW11 INLET 90	1	
E10	FRAME LOWER	3612205501	SGCC T1.0 160X580	1	
E11	BASE U-L	3610392201	SGCC T1.4 100x500	1	
E12	BASE U-R	3610392301	SGCC T1.4 100x500	1	
E13	UNIT DRAIN PUMP AS	36189L5700	40W 110-127V/60HZ B20-3 DRUM(6KG.FILTER) CU	1	DWD-FD'S(110-127/60)
		36189L5K20	AL.220-240/50 B20-6 30W 6KG		DWD-FD'S(220-240/50)
		36189L5J20	AL.220/60 B20-5 35W 6KG		DWD-FD'S(220/60)
E14	CAP WATER REMAIN	3610916800	PP	1	
E15	HOSE WATER REMAIN	3613268700	EPDM, ID8.5, L200	1	
E16	LEG ADJUST AS	3617703811	FOOT + NUT	4	
E17	EMI FILTER	3611909320	K25,MIN7MH,X0.47U.Y222.VAR471K.NON FUSE	1	DWD-FD'S(EU)
E18	CUFF DRAIN HOSE	3616802500	PP	1	
E19	GUIDE DRAIN HOSE	3612510400	PP	1	
E20	HOSE DRAIN INNER AS	3613268401	L=870(changed)	1	
E21	CLAMP HOSE	3611204701	D26	1	
E22	REACTOR AS	3615800100	DWD-800W RT--046B	1	OPTION

■ PLATE T AS + PANEL LOWER AS

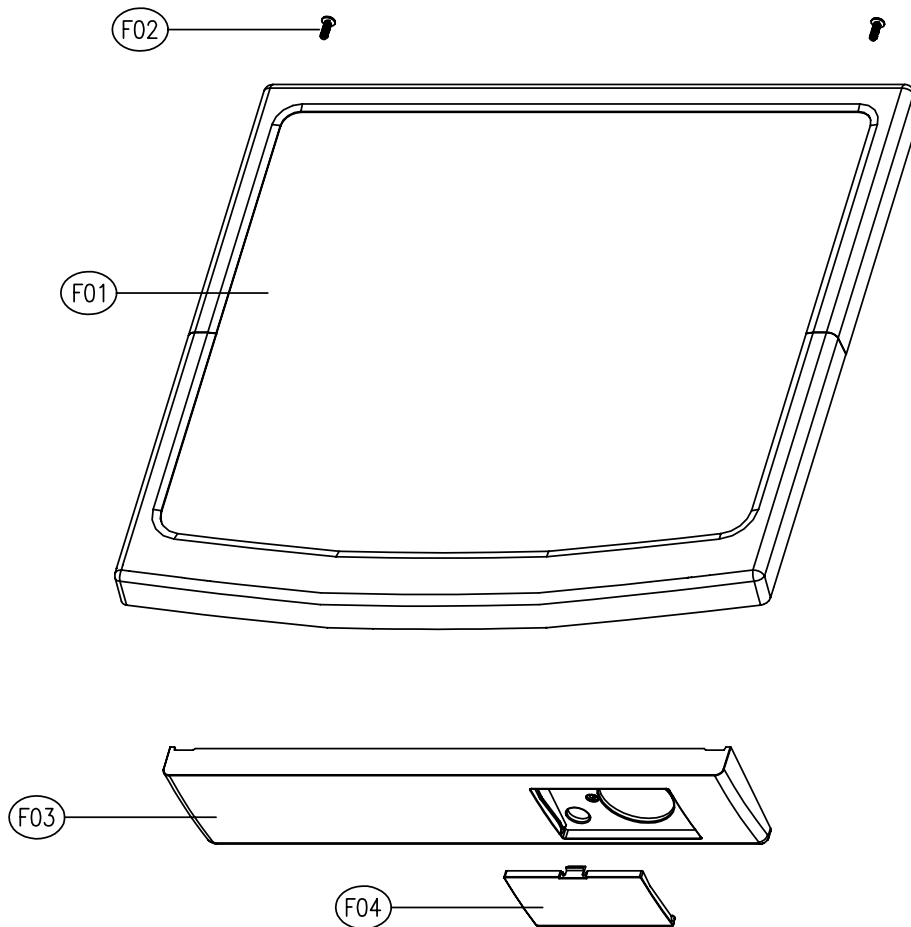





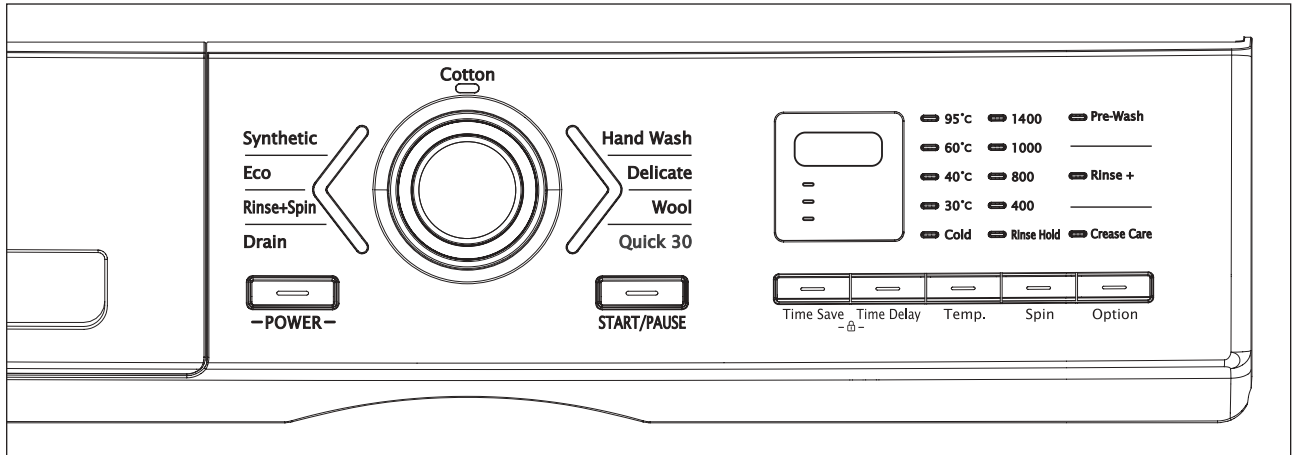

No.	PART NAME	PART CODE	SPECIFICATION	Q'TY	REMARK
F01	PLATE TOP AS	3614532900	DWD-800W(HIPS, MFC, WH)	1	DWD-F1411(2)
		3614532910	ABS+UV SPRAY, MFC, SILVER		DWD-F1413
		3614532920	DWD-F142X(HIPS, MFC, WH)		DWD-F1421(2)
		3614532930	ABS+UV SPRAY, MFC, SILVER		DWD-F1423
		3614533300	FX1X31~2, 41~2(HIPS, MFC, WH)		DWD-F1431(2) DWD-F1441(2) DWD-F1451(2) DWD-F1461(2) DWD-F1471(2)
		3614533310	F3~F4'S, SPRAY(ABS, MFC, SILVER)		DWD-F1433 DWD-F1443 DWD-F1453 DWD-F1463 DWD-F1473
F02	SCREW TAPPING	7122401411	T2S TRS 4x14 MFZN	2	
F03	PANEL LOWER	3614282801	HIPS	1	
F04	COVER PUMP FILTER	3611425801	HIPS	1	

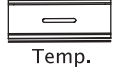
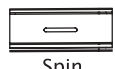

## ■ DWD-FD145X SERIES

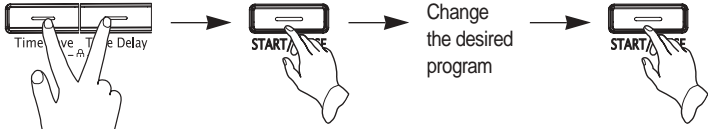
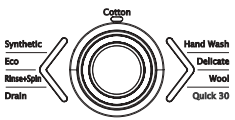

	<p><b>Power Button</b> Press this button to turn the power ON or OFF.</p>
	<p><b>Start/Pause Button</b> This button is use to start wash cycle or stop temporarily. When you want to change program in operating, press this button.</p>
	<p><b>Temperature Button</b> This button can be used to adjust temperature of water according to types of the load to be washed.</p>
	<p><b>Spin Speed Button</b> By pressing this button, the spin speed can be chosen.</p> <p><b>Rinse Hold</b> This function leaves clothes in the machine suspended in the water after a rinse without entering into spin.</p> <p><b>Spin only</b> If you want only spin, you can operate spin only.</p>
	<p><b>Option Button</b> By pressing this button, all option functions may be selected.</p> <p><b>Pre-Wash</b> If the laundry is heavily soiled, Pre-Wash course is effective. Pre-Wash is available in Cotton and Synthetic.</p> <p><b>Rinse+</b> By selecting Rinse+ function, the rinse time and the rinse water are increased.</p> <p><b>Crease Care</b> If you want to prevent crease, select this button with spin speed.</p>

 <p>Time Save</p>	<p><b>Time Save Button</b></p> <p>By pressing this button, you can decrease pre-set washing time to 10 minutes. Time save is available in Cotton, Eco and Synthetic.</p>
 <p>Time Delay</p>	<p><b>Time Delay Button</b></p> <p>If you want to reserve the finishing time of washing, use this button. If the Time Delay button is pressed, '2:00' is displayed. The maximum delayed time is 12:00 hours and the minimum time is 2:00 hours. Each pressing of the button advances on time delay by one hour.</p>
 <p>Time Save Time Delay -A-</p>	<p><b>Child Lock Button</b></p> <p>If you want to protect any accident occurring from handling of washer by a child, use this function. Child Lock can be set by pressing 'Time Save' and 'Time Delay' buttons simultaneously during 2~3seconds.</p> <p><i>* When Child Lock is set, no button functions except Power button.</i></p> <p>To cancel Child Lock, press 'Time Save' and 'Time Delay' buttons simultaneously again.</p> <p>To change to the desired program, while in child lock mode.</p> <ol style="list-style-type: none"> <li>1. Press both 'Time Save' and 'Time Delay' buttons together once again.</li> <li>2. Press the Start/Pause button.</li> <li>3. Select the desired program and press the Start/Pause button again.</li> </ol> 
	<p><b>Program Dial</b></p> <p>When Start/Pause button is pressed, the Cotton program is automatically selected. By turning right the Program Dial, the program is selected in order of 'Cotton ↔ Hand Wash ↔ Delicate ↔ Wool ↔ Quick 30 ↔ Drain ↔ Rinse+Spin ↔ Eco ↔ Synthetic'.</p>

# 7. FUNCTIONS OF THE CONTROLLER

## Sequence Chart

Division		Progress Time	Cotton		Sythetic		Eco	
			Small	Low	Small	Low	Small	Low
PRE WASH	Sensing	20sec.						
	Water Supply	2min.						
	Pre Wash	10min.						
		8min.						
	Drain	1min.						
	B-Spin	1min.						
Middle Spin	3min.							
MAIN WASH	Sensing	20sec.	■	■	■	■	■	■
	Water Supply	2min.	■	■	■	■	■	■
	Wash 1 (Heating)	90min.						
		35min.						
		30min.						
		20min.						
	Wash 2	15min.	■	■	■	■	■	■
		63min.						
		23min.	■	■	■	■	■	■
		13min.	■	■	■	■	■	■
RINSE	Drain	1min.	■	■	■	■	■	■
	B-Spin	1min.	■	■	■	■	■	■
	Middle Spin	4min.	■	■	■	■	■	■
	Water Supply	2min.	■	■	■	■	■	■
	Rinse 1	3min.	■	■	■	■	■	■
	Drain	1min.	■	■	■	■	■	■
	B-Spin	1min.	■	■	■	■	■	■
	Middle Spin	4min.	■	■	■	■	■	■
	Water Supply	2min.	■	■	■	■	■	■
	Rinse 2	3min.	■	■	■	■	■	■
	Drain	1min.	■	■	■	■	■	■
	B-Spin	1min.	■	■	■	■	■	■
	Middle Spin	4min.	■	■	■	■	■	■
	Water Supply	2min.	■	■	■	■	■	■
Rinse 3	3min.	■	■	■	■	■	■	
SPIN	Drain	1min.	■	■	■	■	■	■
	B-Spin	1min.	■	■	■	■	■	■
	Main Spin	7min.	■	■	■	■	■	■
		5min.	■	■	■	■	■	■
	3min.	■	■	■	■	■	■	
END	Untangle	2min.	■	■	■	■	■	■
	End	10sec.	■	■	■	■	■	■
Remained Time Display			1:25	1:30	1:25	1:30	1:40	1:45

### NOTE

- The washing time may vary by the amount of laundry, water pressure, water temperature and other washing conditions. If an unbalanced load is detected or if suds removing program operates, the washing time maybe extended. (Maximum increasing time is about 1 hour.)
- Spin speed 825 rpm is selected automatically with Cotton, Synthetic and Eco courses.

Division	Progress Time	Wool	Delicate	Sports wear	Hand wash	Quick 30	Rinse + Spin	
		Small	1X~5X Small	6X,7X Small	Small	Small	Low	
M A I N  W A S H	Soak	30min.						
	Water Supply	2min.	■	■	■	■ (1min.)		
	Wash 1 (Heating)	60min.						
		50min.						
		35min.						
		30min.						
	Wash 2	5min.					■	
20min.		■	■	(13min.)				
10min.		■	■	■	■			
	5min.	■	■			■		
R I N S E	Drain	1min.	■	■	■	■	■	
	B-Spin	1min.	■	■	■		■	
	Middle Spin	4min.	■	■	■		■	
	Water Supply	2min.	■	■	■	■ (1min.)	■	
	Rinse 1	3min.	■	■	■	■	■	
	Drain	1min.	■	■	■	■		
	B-Spin	1min.	■	■	■			
	Middle Spin	4min.	■	■	■			
	Water Supply	2min.	■	■	■	■ (1min.)		
	Rinse 2	3min.	■	■	■	■		
	Drain	1min.				■		
	B-Spin	1min.				■		
	Middle Spin	4min.				■		
	Water Supply	2min.				■		
	Rinse 3	3min.				■		
S P I N	Drain	1min.	■	■	■	■	■	
	B-Spin	1min.	■	■	■	■	■	
	Main Spin	7min.	■	■	■	■	■	
		5min.	■	■	■	■	■	
	3min.	■	■	■	■	■		
E N D	Untangle	2min.	■	■	■	■	■	
	End	10sec.	■	■	■	■	■	
Remained Time Display			56	56	49	57	33	23

**NOTE**

- The washing time may vary by the amount of laundry, water pressure, water temperature and other washing conditions. If an unbalanced load is detected or if suds removing program operates, the washing time may be extended. (Maximum increasing time is about 1 hour.)
- After the rinse progress in Quick30 course, the washer operating drain progress only without middle spin progress.
- Spin speed 450 rpm is selected automatically with Wool, Delicate(Sports Wear) and Hand Wash courses.
- Apply 'Delicate' course : DWD-FD141X ~ DWD-FD145X models.  
Apply 'Sports Wear' course : DWD-FD146X, DWD-FD147X models.

## Sequence Chart (for apply 'Islamic Rinse' option)

Example) Apply 'Islamic Rinse' option with Cotton/Normal course.

Division		Progress Time	Cotton/Normal		Islamic Rinse Option				
			S (A)	L (B)	S (a)	L (b)			
<b>MAIN WASH</b>	Sensing	20sec.	■	■	Same as 'A'	Same as 'B'			
	Water Supply	2min.	■	■					
	Wash 1 (Heating)	30min.	15min.				■		
			10min.	■			■		
			63min.						
	Wash 2	23min.	13min.	■			■		
<b>RINSE</b>	Drain	1min.	■	■	Same as 'A'	Same as 'B'			
	B-Spin	1min.	■	■					
	Middle Spin	4min.	■	■					
	Water Supply	2min.	■	■					
	Rinse 1	3min.	■	■					
	Drain	1min.	■	■	Same as 'A'	Same as 'B'			
			■	■					
			■	■					
			■	■					
			■	■					
	Water Supply	2min.	■	■	Same as 'A'	Same as 'B'			
			■	■					
			■	■					
			■	■					
			■	■					
Rinse 2	3min.	■	■	Same as 'A'	Same as 'B'				
		■	■						
		■	■						
		■	■						
		■	■						
Rinse 3	3min.	■	■	Same as 'A'	Same as 'B'				
		■	■						
		■	■						
		■	■						
		■	■						
<b>Islamic Rinse 1</b>	Drain	1min.			■	■			
	Water Supply	2min.			■	■			
	Rinse (with Water Supply and Drain)	3min.			■	■			
	B-Spin	1min.			■	■			
	Middle Spin	4min.			■	■			
<b>Islamic Rinse 2</b>	Water Supply	2min.			■	■			
	Rinse (with Water Supply and Drain)	3min.			■	■			
<b>SPIN</b>	Drain	1min.	■	■	Same as 'A'	Same as 'B'			
	B-Spin	1min.	■	■					
	Main Spin	7min.	■	■					
			■	■					
			■	■					
<b>END</b>	Untangle	2min.	■	■					
	End	10sec.	■	■					
<b>Remained Time Display</b>			1:25	1:30	1:41	1:46			

### NOTE

- Islamic Rinse is available in Cotton, Synthetic, Hand Wash and Sports Wear programs.
- By selecting Islamic Rinse function, the washer operates two additional rinse times (Islamic Rinse process 1 and 2) after the basic rinse process. And then the washing time will be extended about 16 minutes.

## 8. FUNCTION OF THE CONVENIENT SERVICE

### ■ The test mode of the operation

You can check the PCB AS and the operation of the washing machine simply.

#### • The method to test and operate

- ① Press the Power button.
- ② Press the Option button 3 times while press the Temp button.  
At this time, the version is displayed on the Custom LED
- ③ Whenever the Time Delay button is pressed, the washing machine is operated as following.  
L\_C (Lock Switch Close) → run/OO (The number of running times)  
→ E5/OO → E6/OO → E7/OO → E8/OO (The number of the error occurrence)  
→ H (Hot Valve) → C (Cold Valve) → P (Pre-Wash Valve)  
→ bb (Bubble) → dr (Drain Pump)  
→ C:H or C:-- (Cold & Hot Option)  
→ nPC or PC or etc. (PCB Option) → L\_O (Lock Switch Open)  
→ L\_C → ... (repetition)

### ■ The check mode of the water level frequency

You can check the water level frequency of the current state and the frequency by the variation of the water level.

#### • The method to test and operate

- ① Press the Power button.
- ② Press the Time Delay button 3 times while press the Temp button and the Spin button.
- ③ The water level frequency of the current state displays on "18:88 LED".

ex) **5 6 2** = 25.62kHz

: It display three number except the first number of 25.62kHz

- ④ Whenever the Temp button is pressed, the washing machine is operated as following.  
Cold Valve Off (Initial state)  
→ Cold Valve On  
→ Hot Valve On  
→ Pre-Wash Valve On  
→ Bubble Pump On  
→ Drain Pump On  
→ ... (repetition)

## ■ The spinning test mode

You can continually spin the washing machine with constant speed.

### • The method to test and operate

- ① Press the Power button.
- ② Press the Time Save button 3 times while press Temp button.
- ③ '400' displays on '18:88 LED'. 400 means the spinning rpm.  
You can adjust the spinning rpm by pressing Spin button.  
And this value increases by 20 up to 1520.
- ④ When press Start button, the washing machine continually operates with given spinning rpm.

## ■ The durability test mode

You can repetitively operate the washing machine with one course.

### • The method to test and operate

- ① Press the Power button.
- ② Press the Time Delay button 3 times while press Temp button.
- ③ 'd3' displays on '18:88 LED'. You can select the course by using Program Dial, Temp button, Spin button, Option and Time Save button.
- ④ When press Start button, the washing machine repetitively operates with selected course.

## 9. TROUBLESHOOTING GUIDE

This washing machine is equipped with automatic safety function which detect and diagnose faults at an early stage and react appropriately.

When the machine does not function properly or does not function at all, check the following points.

SYMPTOM	CAUSE	SOLUTION
Rattling and clanking noise.	Foreign objects such as coins or safety pins maybe in the drum or pump.	Stop washer and check drum and filter.
Thumping sound.	Heavy wash loads may produce a thumping sound. This is usually normal.	If sound continues, washer is probably out of balance. Stop and redistribute wash load.
Vibrating noise.	Have all the transit bolts and packing been removed?	If not removed during installation, refer to installation guide for removing transit bolts.
	Are all the feet resting firmly on the ground?	Wash load may be unevenly distributed in drum. Stop washer and rearrange wash load.
Water leaks.	Inlet hoses or drain hose are loose at tap or washer.	Check and tighten hose connections.
	House drain pipes are clogged.	Unclog drain pipe. Contact plumber if necessary.
Oversudsing.		Too much detergent or unsuitable detergent may cause excessive foaming which may result in water leaks.
Water does not enter washer or it enters slowly.	Water supply is not adequate in area.	Check another tap in the inlet house.
	Water supply tap is not completely open.	Fully open tap.
	Water inlet hose is kinked.	Straighten hose.
	The filter of the water inlet is clogged.	Check the filter of the water inlet.
Water in the washer does not drain or drains slowly.	Drain hose is kinked or clogged.	Clean and straighten drain hose.
	The drain filter is clogged.	Clean the drain filter.



SYMPTOM	CAUSE	SOLUTION
Washer does not start.	Electronical power cord may not be plugged in or connection may be loose.	Make sure plug fits tightly in wall outlet.
	House fuse blown, circuit breaker tripped, or a power outage has occurred.	Reset circuit breaker or replace fuse. Do not increase fuse capacity. If problem is a circuit overload, have it corrected by a qualified electrician.
	Water supply tap is not turned on.	Turn on water supply tap.
Washer will not spin.	Check that the door is firmly shut.	Close the door and press the Start/Pause button. After pressing the Start/Pause button, it may take a few moments before the clothes washer begins to spin. The door must lock before spin can be achieved.
Door does not open.		Once started, the door can not be opened for safety reasons. Wait two minutes before opening the door to give the electric locking mechanism time to release.
Wash cycle time delayed.		The washing time may vary by the amount of laundry, water pressure, water temperature and other usage conditions. If the imbalance is detected, the wash time shall be increased.
The washer will stop during spinning . Spinning is insufficient.	PFE error due to much detergent and unsuitable detergent.	If PFE error mode was displayed on the control part, in order to solve this problem, first turn off the power of the washing machine, second turn on the power pressing Power button, third press SPIN button and last press Start/Pause button.

MESSAGE	ERROR	CAUSE	SOLUTION
IE	WATER INLET ERROR	The water tap is closed.	Open the water tap.
		The filter of the valve inlet is clogged.	Clean the filter of the valve inlet.
		The valve inlet is an inferior product or broke down.	Change the valve inlet.
		The water level sensor (sensor pressure) is an inferior product or broke down.	Change the water level sensor (sensor pressure).
		The drain motor works during water supply.	Change the drain motor.
		The PCB ASS'Y does not check the water level.	Change the PCB ASS'Y.
OE	DRAIN ERROR	The drain hose is kinked or clogged.	Clean and straighten the drain hose.
		The drain motor is an inferior product.	Change the drain motor.
		The valve inlet works during drain.	Change the valve inlet.
		The water level sensor is an inferior product.	Change the water level sensor.
		The PCB ASS'Y does not check the water level.	Change the PCB ASS'Y.
UE	UNBALANCE ERROR	The laundry is concentrated to one side of the drum during spin.	Rearrange the laundry.
LE	DOOR OPEN ERROR	The Start/Pause button is pressed while the door is opened.	Close the door.
		The switch door lock is an inferior product.	Change the switch door lock.
		The PCB ASS'Y does not check the door lock.	Change the PCB ASS'Y.
E2	OVERFLOW ERROR	The water is supplied continuously due to an inferior valve inlet.	Change the valve inlet.
		The valve inlet is normal, but the water level sensor (sensor pressure) is inferior.	Change the water level sensor (sensor pressure).
		The drain motor does not work. (The drain motor is an inferior product or broke down.)	Change the drain motor.
E4	LEAKAGE ERROR	Water leaks from the tub or the hose drain.	Check the leak of the tub or the hose drain. Then change the tub or the hose drain.
E5	HIGH VOLTAGE ERROR	The laundry is jammed between the gasket and the drum.	Rearrange the laundry.
		The PCB ASS'Y is an inferior product.	Change the PCB ASS'Y.
E6	EMG ERROR	The laundry is jammed between the gasket and the drum.	Rearrange the laundry.
		The motor is an inferior product.	Change the motor.
		The PCB ASS'Y is an inferior product.	Change the PCB ASS'Y.
E8	MOTOR ERROR	The motor is not normally connected.	Check the connector of the motor.
		The motor does not work. (The motor is an inferior product or broke down.)	Change the motor.
E9	SENSOR PRESSURE ERROR	The water level sensor is an inferior product.	Change the water level sensor.
H2	THERMISTOR WASH ERROR	The thermistor wash is an inferior product or broke down.	Change the thermistor wash.
		The thermistor wash is not connected normally.	Check the connector of the thermistor wash.
H4	THERMISTOR WASH OVERHEATING ERROR	The heater worked without the water in the tub.	Check the water level.
		The thermistor wash is an inferior product or broke down.	Change the thermistor wash.

MESSAGE	ERROR	CAUSE	SOLUTION
H5	WATER TEMP. ERROR	The water temp. is over 45°C in delicate & wool course. (The thermistor wash is an inferior product or broke down.)	Change the thermistor wash.
H6	HEATER WASH ERROR	The heater wash dose not work. (The water temp. doesn't rise over 2°C during 15min.)	Change the heater wash.
H8	HEATER WASH OVERHEATING ERROR	The heater worked without the water in the tub.	Check the water level and the heater wash.
lb	IGBT ERROR	The PCB ASS'Y is an inferior product.	Change the PCB ASS'Y.
PFE	PUMP FILTER ERROR	The drain pump filter is clogged.	Clean the drain pump filter.
		The drain pump does not work during spin.	Change the drain pump.
		The large amount of detergent was used.	Use the proper amount of detergent.
		The drain hose is placed higher than 1m above the floor.	Place the drain hose 1m below the floor.

# 10. WIRING DIAGRAM

