

ELECTRICAL FUNCTIONS

C1

1- MAIN BOARD

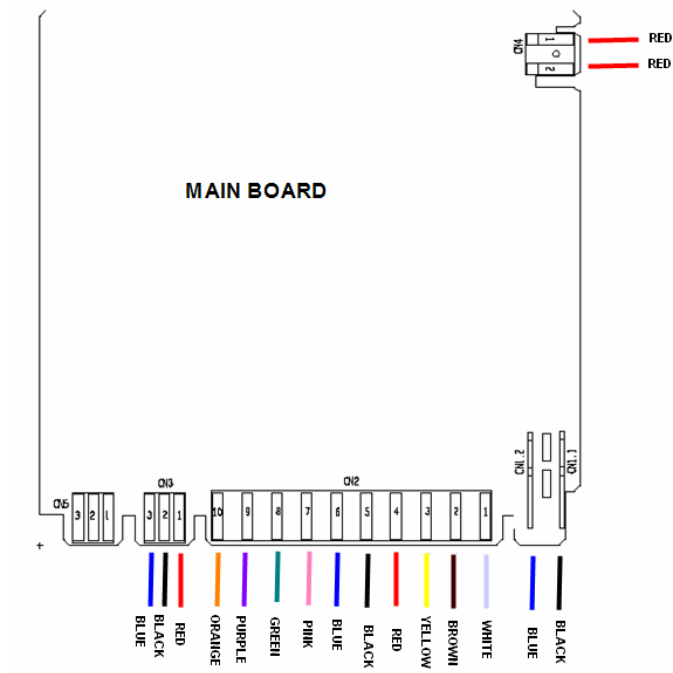

2- ELECTRICAL ABBREVIATIONS

FM	FLOWMETER
SET	NTC SENSOR
IV	INLET VALVE
FS	FLOAT SENSOR
DP	DRAIN PUMP
PS	PRESSURE SWITCH
DS	DOOR SWITCH
DE	DETERGENT
HE	HEATING ELEMENT
CP	CIRCULATION PUMP
C	CAPASITOR
RV	REJENERATION VALVE
SF	HEATING SAFETY

3- BASIC CIRCUIT DIAGRAM

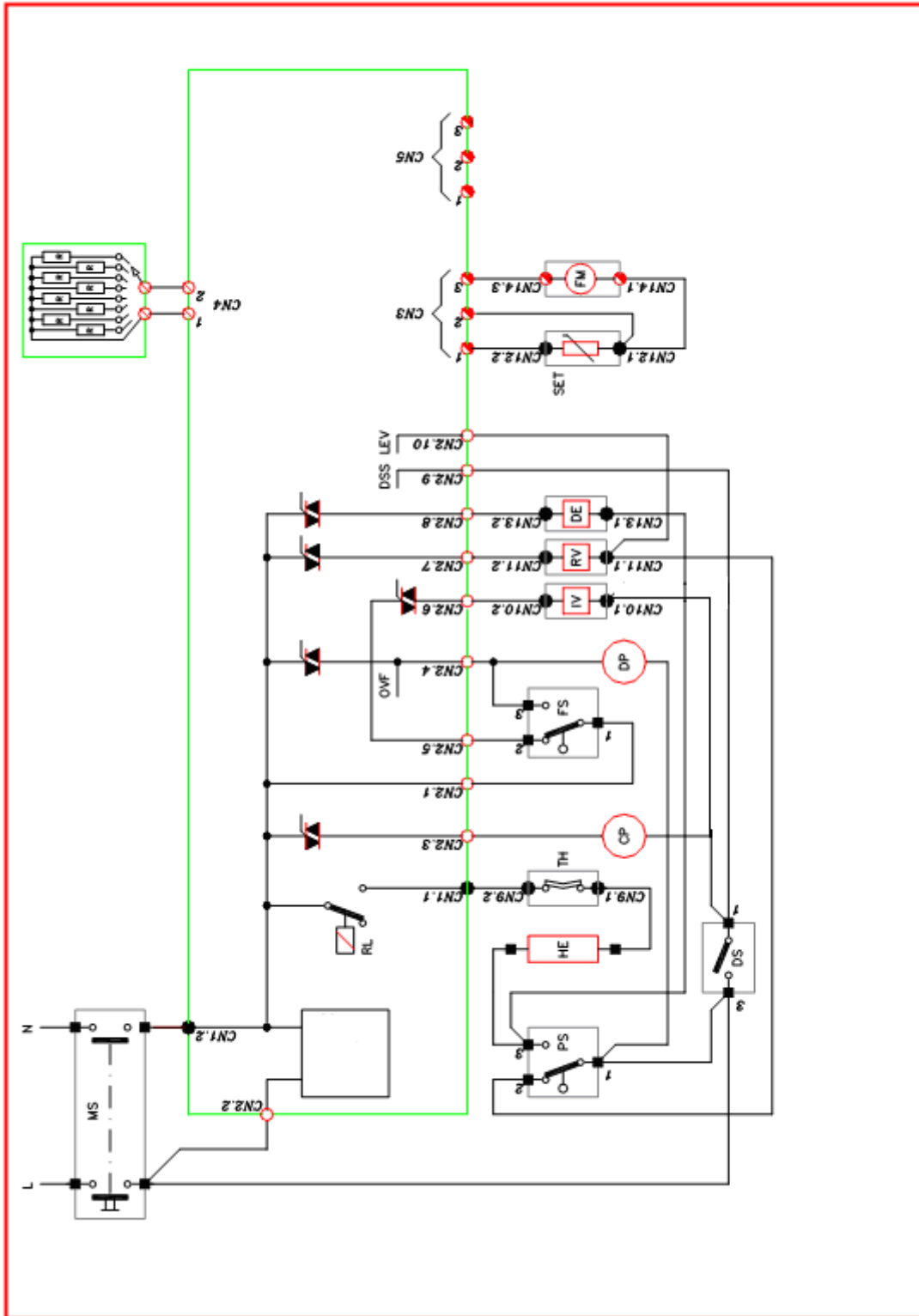

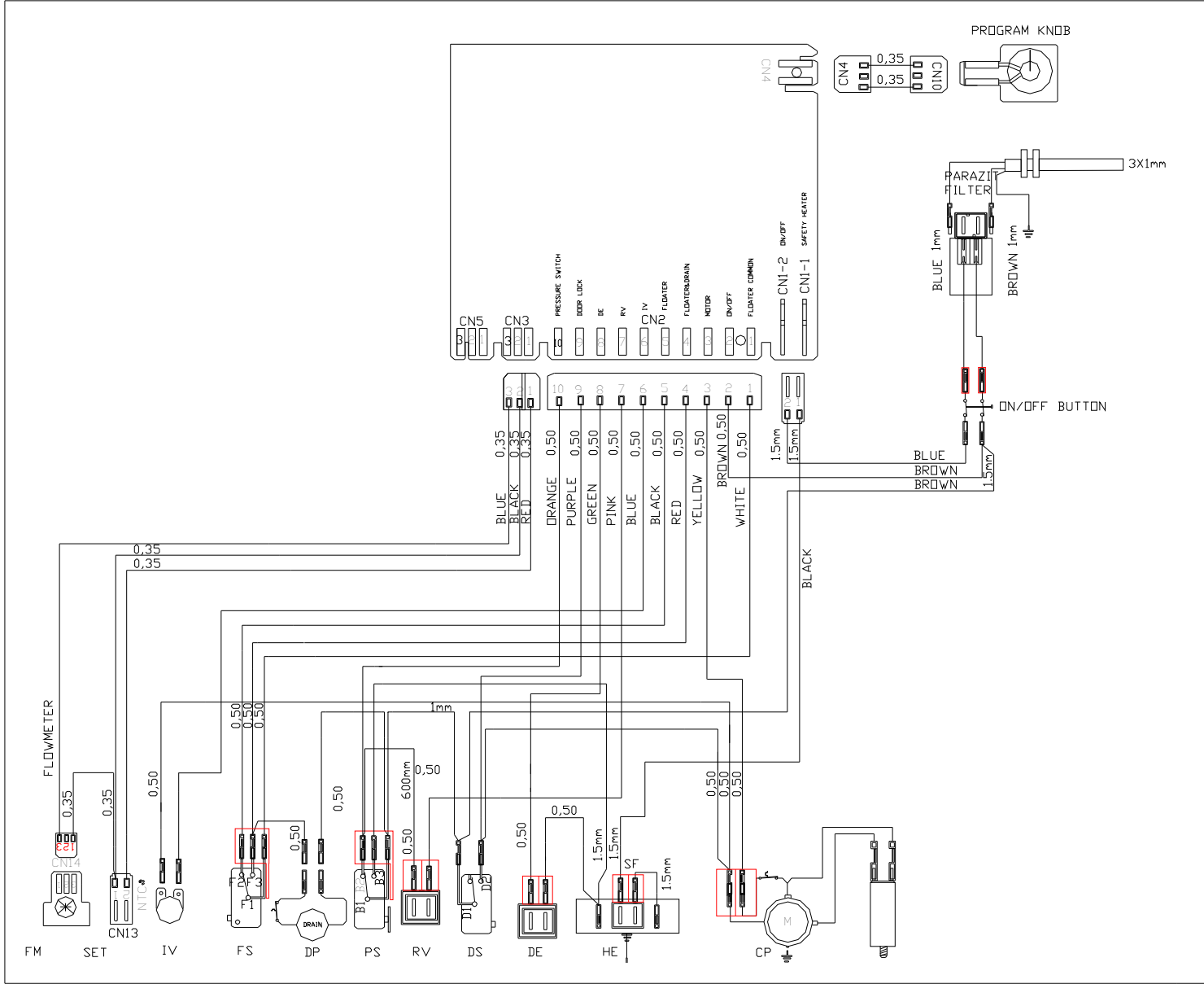

4 - CIRCUIT DIAGRAM