

NO	PART NAME
300	LOWER BASKET GROUP (45)
301	LOWER BASKET WHEEL GROUP/45
360	UNIVERSAL BASKET GR-7046

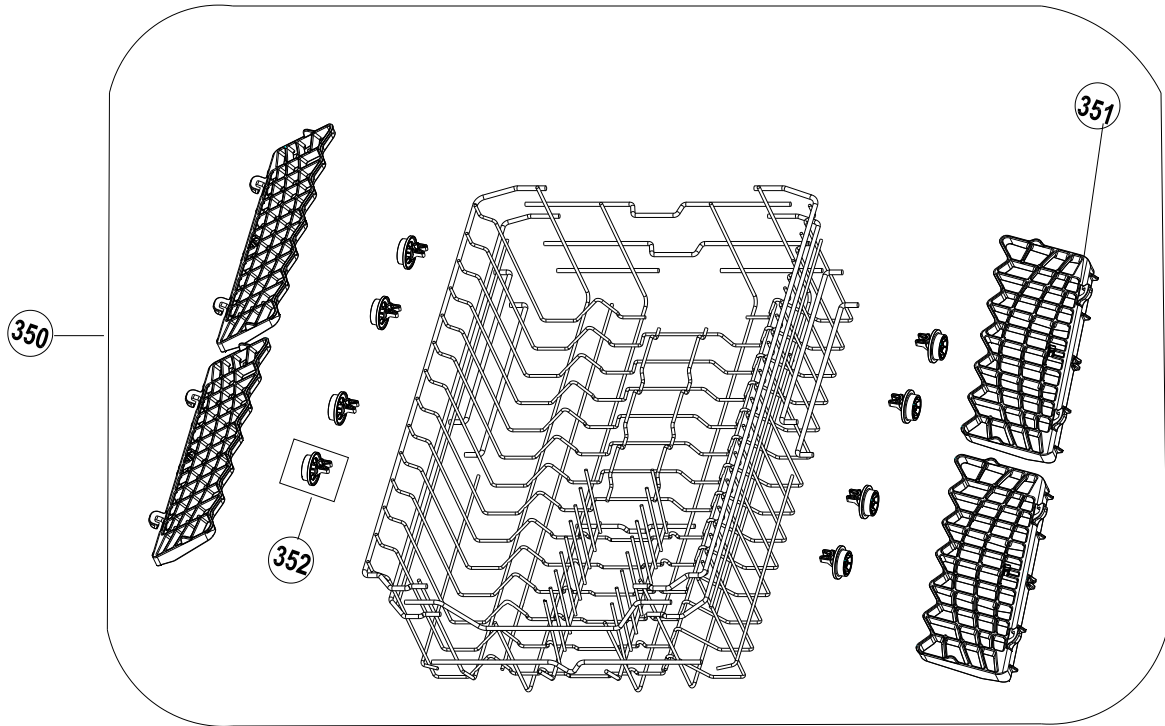

NO	PART NAME
350	UPPER BASKET (45)GROUP-42 (351 - 352 - )
351	MUG SHELVE/45
352	UPPER BASKET WHEEL GROUP

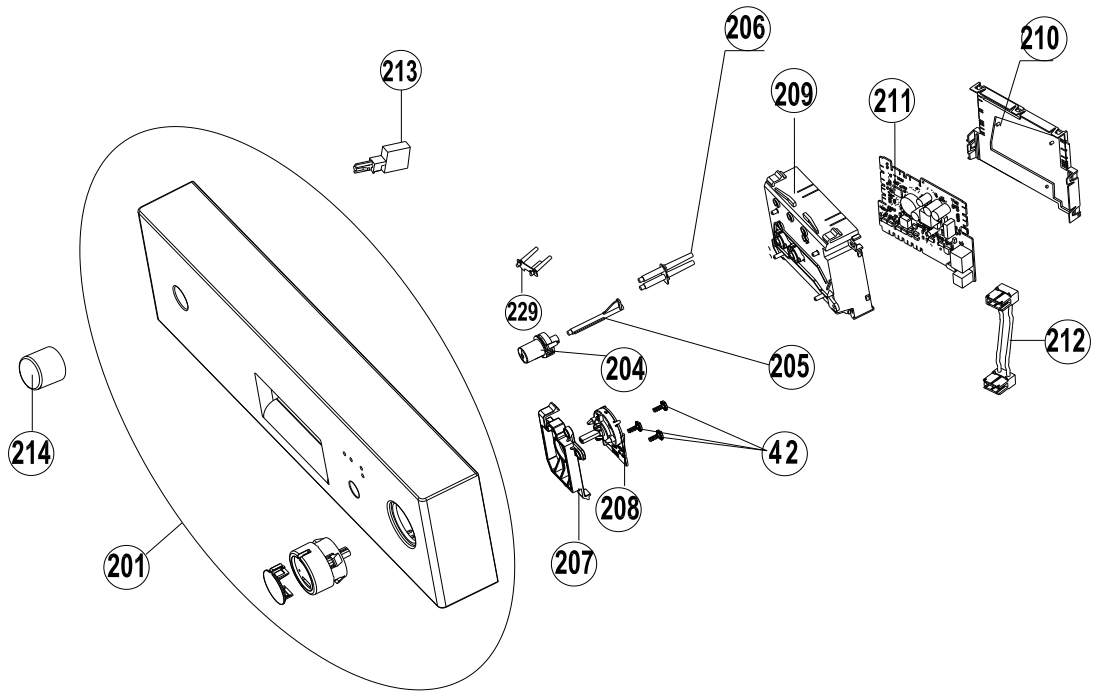

NO	PART NAME
200	CON.PAN.GROUP ( 201-204-205-206-207-215-216-208-209-210-230-42 )
201	CON.PAN.PRINTED
204	ELECTRONIC BUTTON-1
205	ELEKTRONIC BUTTION SHAFTI-1
206	LIGHT GUIDE-2
207	ROTARY SWITCH CONNECTION PLS.
208	ROTARY SWITCH
209	PCB BOX-1 BODY
210	PCB BOX-1 REAR COVER
211	ELECT.CARD
212	ROTARY SWITCH CABLE
213	ON-OFF SWITCH
214	ON/OFF BUTTON
42	SCREW PT3,5X9 YSB

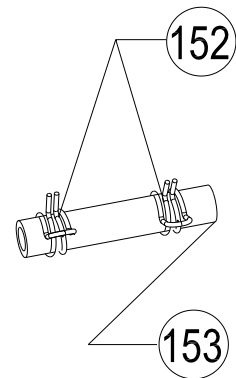
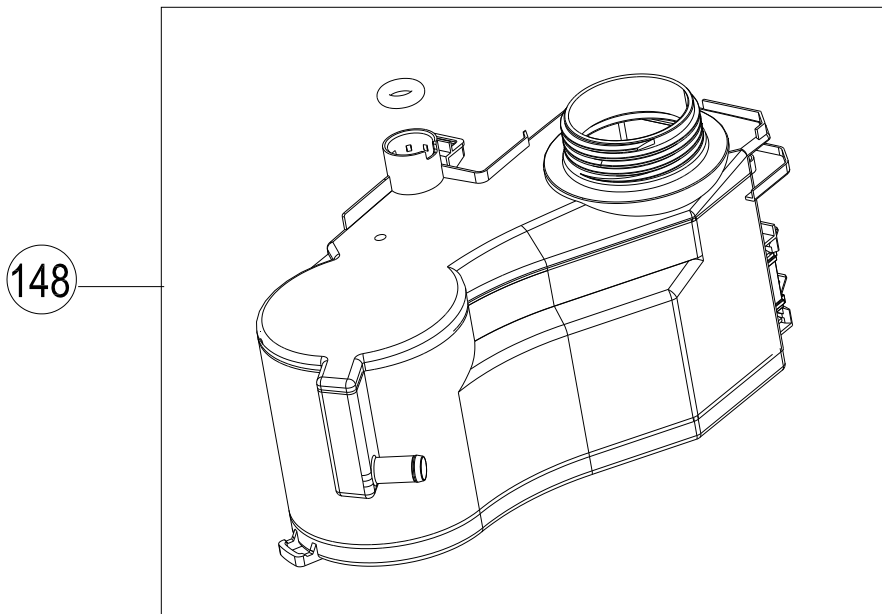
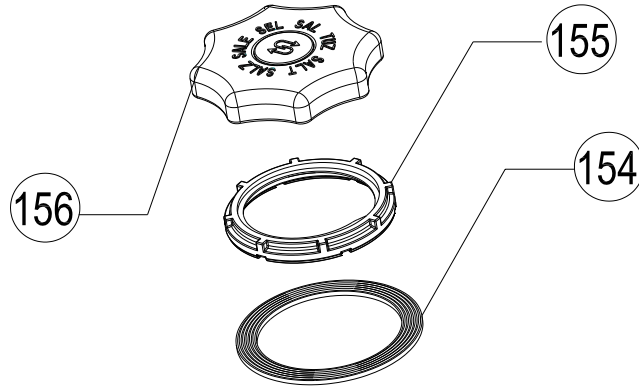

NO	PART NAME
148	WATER SOFTENER GR WITH REED RELAY/45
152	CLAMP Dmax16,8x8,4
153	HOSE D10,5*3*86,6
154	WATER SOFTENER NUT GASKET
155	WATER SOFTENER NUT RAL-7046
156	SALT CAP GR(MAGNETIC)RAL-7046

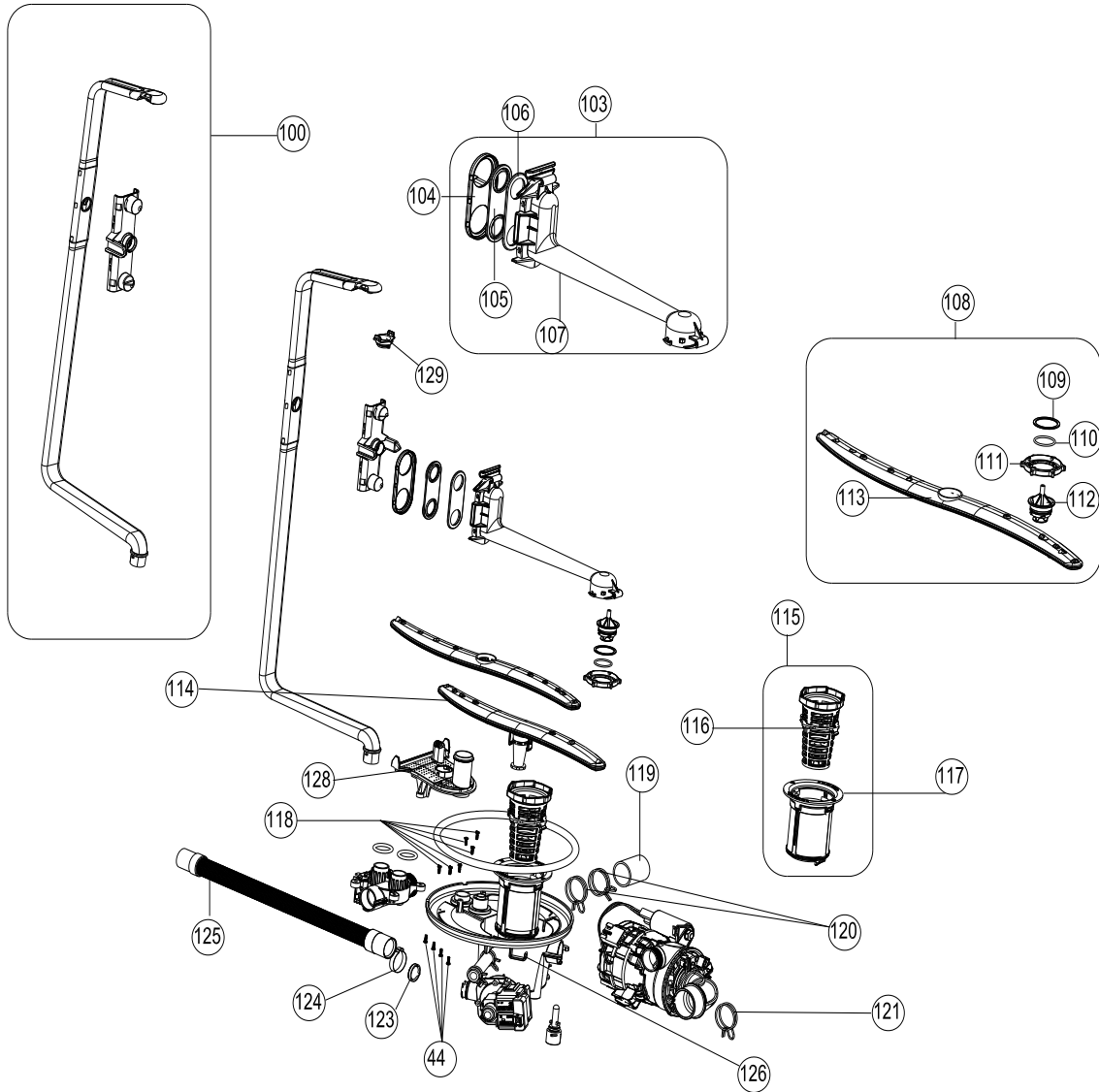

NO	PART NAME
100	UPPER SPRAY ARM FEEDING CANAL GROUP-C
103	<b>UPPER SPRAY ARM SUPPORT GROUP( 104-105-106-107 )</b>
104	UPPER SPRAY ARM ADAPTER COVER
105	UPPER SPRAY ARM ADAPTER GASKET
106	UPPER SPRAY ARM ADAPTER FLANGE
107	UPPER SPRAY ARM SUPPORT
108	<b>UPPER SPRAY ARM GROUP(113-112-111-110-109)</b>
109	UPPER SPRAY ARM NUT PLASTIC
110	UPPER SPRAY ARM SHAFT O-RING
111	UPPER SPRAY ARM NUT
112	UPPER SPRAY ARM SHAFT
113	UPPER SPRAY ARM

NO	PART NAME
114	LOWER SPRAY ARM
115	<b>MICROFILTER GROUP( 116-117 )</b>
116	COURSE FILTER
117	MICROFILTER
118	SCREW PT4X12 YSB INOX
119	HOSE D29.5X2.5
120	CLAMP Dmax36,4X14
121	CLAMP Dmax41X14,8
123	KLAPE
124	HOSE HANDCUFFS D30
125	DRAIN HOSE 200 CM
126	SUMP/45
127	SUMP SEAL
128	SPRAY ARM SUPPORT
129	TOP NOZZLE
44	VIDAPT4X12YSB

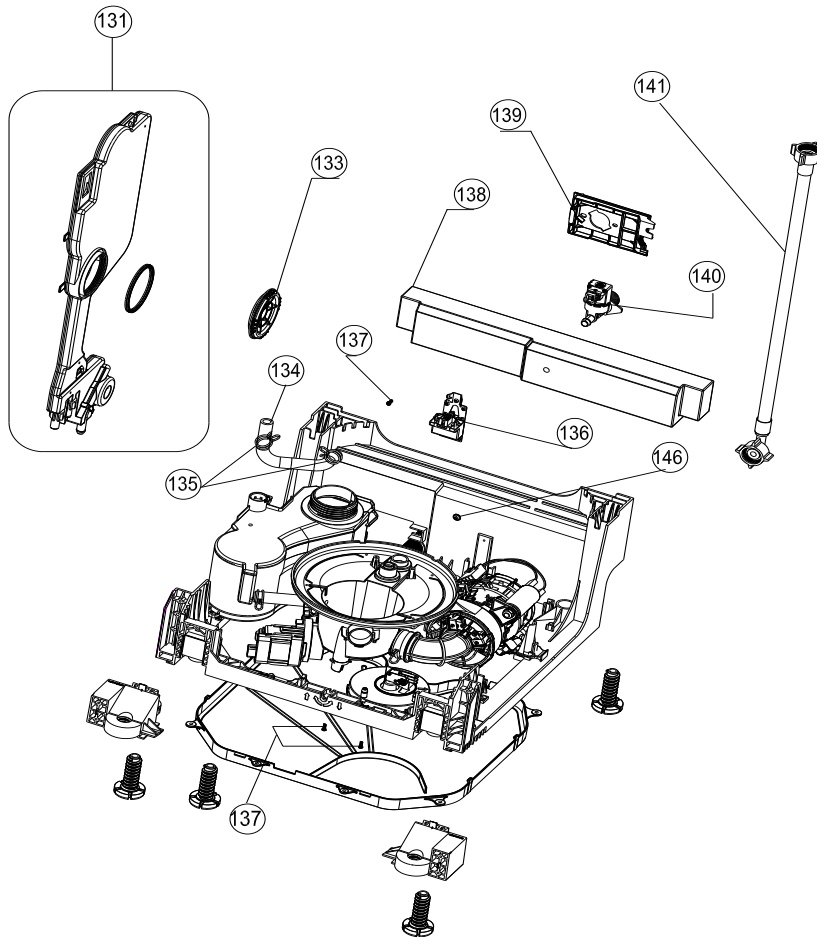

NO	PART NAME
131	AIR BREAK GROUP
133	AIR BREAK NUT
134	HOSE D10*3*230 PVC/WITH CORD
135	CLAMP Dmax16,8x8,4
136	PARASITE FILTER
137	SCREW PT3X9 YSB
138	CONCRETE WEIGHT
139	BASEMENT HOSE.CON.PLS.
140	WATER INLET VALVE
141	WATER INLET HOSE GROUP
53	SCREW 4X42,5 YHB

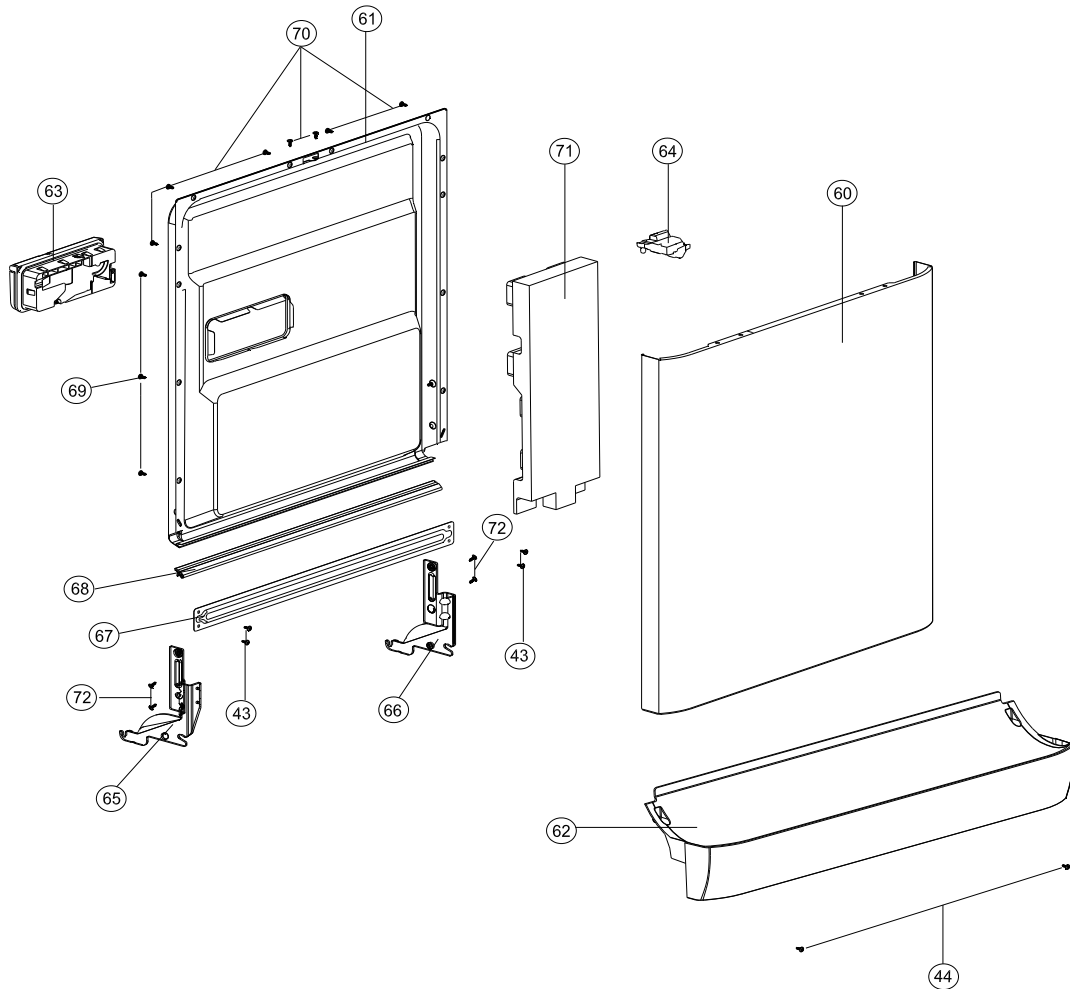

NO	PART NAME
60	DOOR OUTSIDE
61	DOOR INSIDE SHEETIRON GROUP
62	PLASTIC KICK PLATE
63	DISPANSER WITHOUT REED RELAY
64	DOOR LOCK
65	HINGE MOVEMENT SHEETIRON LEFT
66	HINGE MOVEMENT SHEETIRON RIGHT
67	TWISTED SHEETIRON
68	DOOR SEAL
69	SCREW ST 3,9X12 FLAT HEAD INOX
70	SCREW PT4X14 FLAT HEAD INOX
71	DOOR SUPPORT STYROFOAM
72	SCREW M5X10 TORK HEAD (S)
43	SCREW M4X9 PAN HEAD (S)
44	SCREW PT 4X12 PAN HEAD COLLAR CROSS



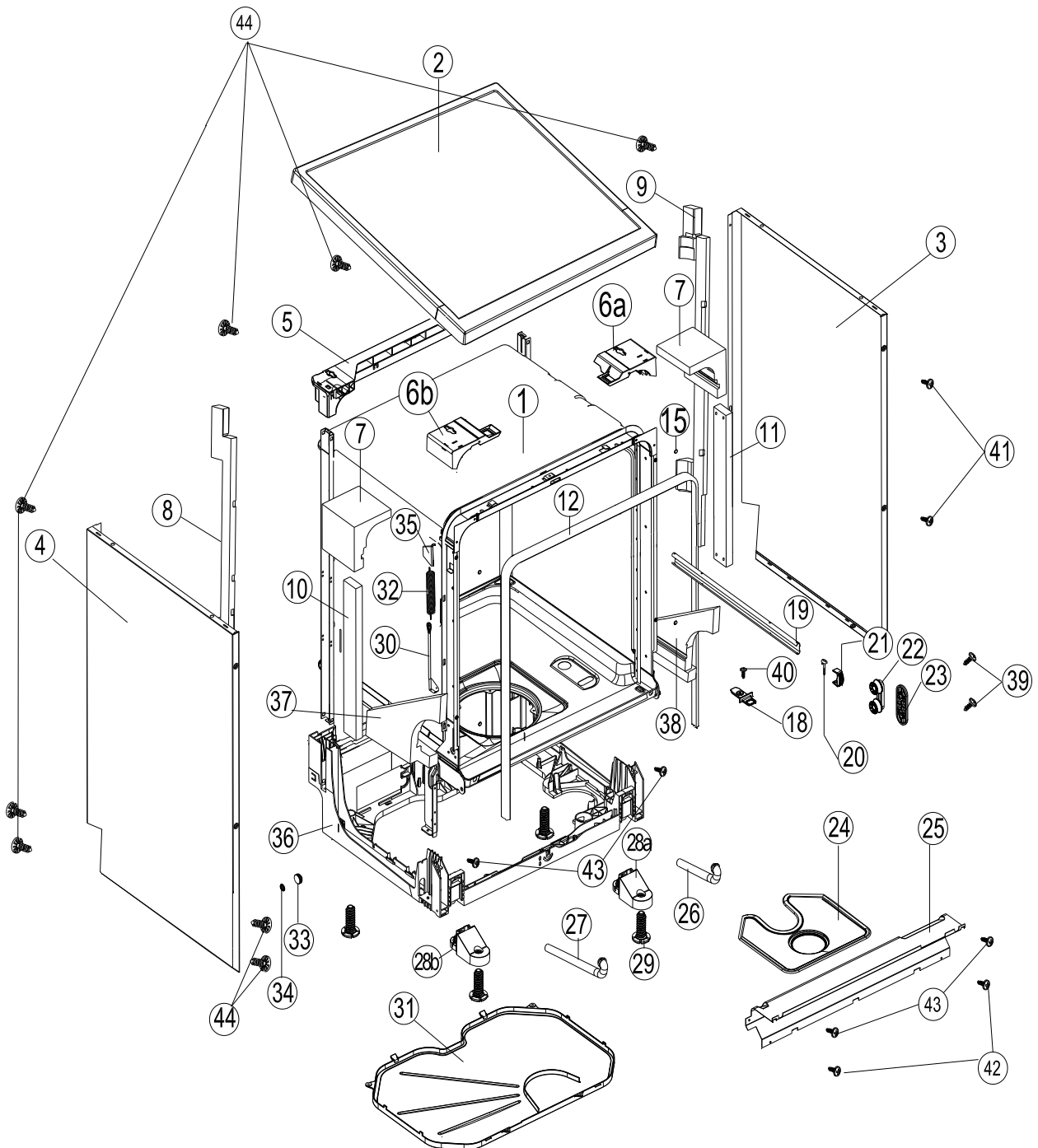

NO	PART NAME
1	TUBE ASSEMBLY
2	UPPER TRAY GROUP
3	FLAT/SIDE PANEL SHEETIRON-RIGHT
4	FLAT/SIDE PANEL SHEETIRON-LEFT

**NOTE-3: The spare part with poz no 15 is not valid from 09.07.2012**

NO	PART NAME
5	REAR UPPER PLS.CROSS BAR
6a	UPPER TRAY SUPPORT PART - RIGHT
6b	UPPER TRAY SUPPORT PART - LEFT
7	TUB TOP CORNER STYROFOAM
8	BACK CROSS BAR STYROFOAM-LEFT
9	BACK CROSS BAR STYROFOAM-RIGHT
10	FRONT CROSS BAR STYROFOAM-LEFT
11	FRONT CROSS BAR STYROFOAM-RIGHT
12	TUB GASKET
15	SIDE PANEL FRONT CROSS BAR SCREW CUPS
18	BOTTOM CORNER GASKET-LEFT
19	UPPER BASKET RAIL
20	UPPER BASKET STOPPER-REAR
21	UPPER BASKET RAIL LOCK-FRONT
22	UPPER BASKET RAIL CON.BRA.GROUP
23	UPPER BASKET RAIL CON.BRA -REAR
24	METAL FILTER
25	KICKPLATE SHEETIRON
26	OVERFLOW PIECE FROM TUB WITH HOSE/265mm
27	OVERFLOW PIECE FROM TUB WITH HOSE/405 mm
28a	FRONT FOOT CONN.PART-2 RIGHT
28b	FRONT FOOT CONN.PART-2 LEFT
29	ADJUSTED FOOT
30	HINGE CORD GROUP
31	LOWER COVER
32	HINGE SPRING
33	HINGE PULLEY
34	FIXED PULLEY SEG.
35	SPRING CONNECTION PART
36	BASEMENT
37	TUB LOWER CORNER STYROFOAM-LEFT
38	TUB LOWER CORNER STYROFOAM-RIGHT
39	SCREW PT5X20 TORX COLLAR CROSS
40	SCREW M4X6
41	SCREW 3,9X9,5 FLAT HEAD
42	SCREW PT3,5X9 PAN HEAD
43	SCREW M4*9 SB PAN HEAD ( S )
44	SCREW PT4X12 PAN HEAD COLLAR CROSS

JULY 2012

**COMPONENTS**

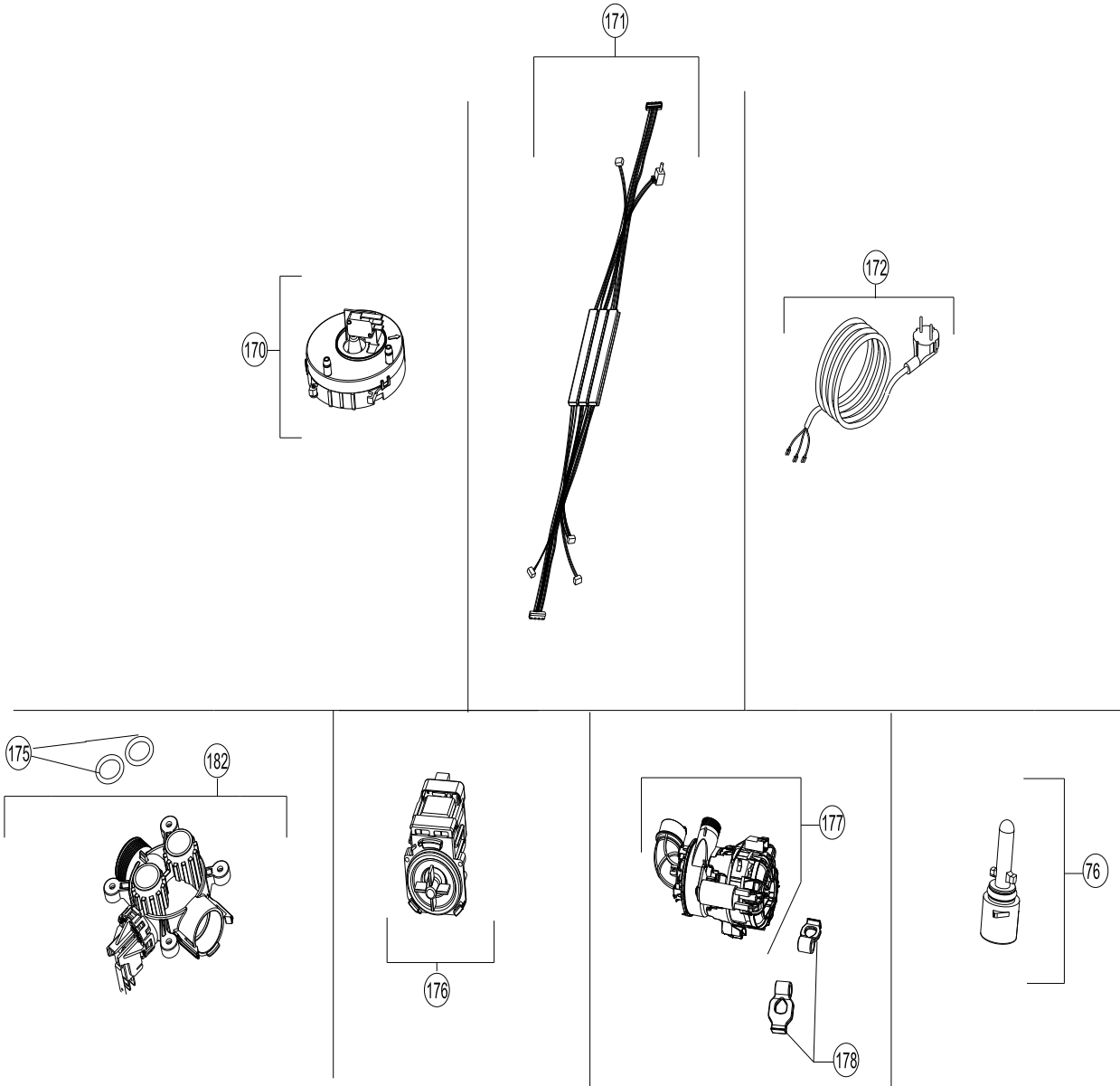

NO	PART NAME
170	FLOATER
171	CABLE HARNESS
172	POWER CABLE 180cm/WHITE
175	HEATER CASING O-RING
176	DRAIN PUMP
177	WASHING PUMP
178	WASHING PUMP VINE SUPPORT
182	ECO
76	NTC